

联系我们获取技术支持或售后服务 Obtain services or technical support

制造公司: 广东衡天下检测设备有限公司

公司地址: 广东省东莞市东城街道桑园长乐路13号

服务热线: 400-110-0916

Manufacturing Company: Guangdong Hengtianxia Testing Equipment Co., Ltd.

Company Address: No. 13 Changle Road, Sangyuan, Dongcheng Street, Dongguan City, Guangdong Province

Service Hotline: +86 13560805384

重要说明 Important Notes

我司对本说明文档中的错误和疏忽不负任何责任, 文档中的信息可能随时会发生变更, 恕不另行通知。

如果用户对本设备的安装、调试、操作或维修存有任何疑惑, 应联系我司的业务或售后。

文档版本号: 20251107-0

Our company shall not be liable for any errors or omissions in this documentation. The information contained herein is subject to change without prior notice.

If you have any doubts regarding the installation, commissioning, operation, or maintenance of this equipment, please contact our sales or after-sales service team.

Document Version No.: 202511

标准型系列检重分选设备使用说明

Standard Series Checkweigher



说明文档适用机型 Applicable Models of the Documentation

衡天下品牌的标准型系列动态检重秤、重量分选机适用，部分定制型检重秤亦适用。

Applicable to HTX standard checkweighers, weight sorters, and some customized types.

说明书目录	catalogue	2
1.前言	1.Preface	3
- 1.1 安全须知	- 1.1 Safety Instructions	3
- 1.2 运转时注意事项	- 1.2 Operational Precautions	4
- 1.3 动态检重机概要	- 1.3 Overview of Dynamic Checkweigher	5
2.安装事项	2.Installation Matters	6
- 2.1 技术参数	- 2.1 Technical Parameters	6
- 2.2 安装前检查	- 2.2 Pre-installation Inspection	7
- 2.3 安装环境	- 2.3 Installation Environment	7
- 2.4 注意事项	- 2.4 Precautions	7
- 2.5 传送带的安装	- 2.5 Conveyor Belt Installation	8
- 2.6 传送带的调整	- 2.6 Conveyor Belt Adjustment	8
3.用户指南	3.User Guide	9
- 3.1 触摸屏主界面	- 3.1 Touch Screen Main Interface	10
- 3.2 功能检查	- 3.2 Function Check	11
4.参数设置	4.Parameter Setting	12
- 4.1 标定	- 4.1 Calibration	12
- 4.2 用户登录	- 4.2 User Login	13
- 4.3 参数设置	- 4.3 Parameter Setting	14
5.维护保养	5.Maintenance	17
- 5.1 日常维护	- 5.1 Routine Maintenance	17
- 5.2 设备清洁	- 5.2 Equipment Cleaning	18
- 5.3 故障处理	- 5.3 Troubleshooting	18
6.电路图	6.Circuit Diagram	22

1.前言 Preface

此操作手册就标准型机器的系统启动、重量设置、标定、系统设定的操作方法进行说明。

为保证设备的长期安全、高效的正常运转状态, 在对本设备进行运转操作或进行设置之前, 请事前细读。

This operation manual explains the operating methods for system startup, weight setting, calibration, and system configuration of the Standard Series machines.

To ensure the equipment operates safely, efficiently, and reliably for a long time, please read this manual carefully before operating or configuring the device.

本设备安装使用条件如下所示:

The installation and operating conditions of this equipment are as follows:

使用温度	-10°C至40°C	Operating Temperature: -10°C to 40°C
使用湿度	35至85%(不接露)	Humidity: 35% to 85% (No Condensation)
安装场所	选择坚固平稳场地进行安装	Installation Site: Choose a Solid and Level Area
工作电源	AC220V ±10%单相 50/60Hz	Power Supply: AC220V ±10% Single-phase 50/60Hz
接地	第3类接地或同等条件	Grounding: Class 3 Grounding or Equivalent

1.1 安全须知 Safety Instructions

设备安装的建筑场地应该充分的支撑本设备及其周边设备的强度, 并且考虑到日常操作运转的方便以及售后服务所需要的充分照明度。



危险:切勿将检重机置于有产生可燃性气体以及易燃、易爆的作业环境中。非定制型不具备防爆功能。

Danger: Do not place the checkweigher in working environments where flammable gases, flammable substances, or explosive materials are present. Non-customized models do not have explosion-proof functions.

电源:根据用户当地的电压连接,标准型系列检重秤一般为AC220V ±10%单相 50/60Hz。

重要:标准系列检重机要求一个可靠的、永久的接地。



Power Supply: Connect in accordance with the local voltage. The Standard Series Checkweigher is generally rated for AC220V ±10% single-phase, 50/60Hz.

Important: The Standard Series Checkweigher requires a reliable and permanent ground connection.

设备的开箱检查: 当你收到包装好的设备时, 要检查整个的货物有无损伤。如有损伤请拍照取证, 并立刻向运货商提出书面的处理要求。

重要: 请务必对木板箱内取出的货物和运货商提供的装箱清单进行比较与核实。

Unpacking Inspection of the Equipment: When you receive the packaged equipment, inspect the entire shipment for any damage. If damage is found, take photos as evidence and immediately submit a written claim to the logistics provider.

Important: Be sure to compare and verify the items removed from the wooden crate with the packing list provided by the logistics provider.

设备搬运: 请提供完整的运输设备进行搬运, 搬运时注意设备的重心。务必在将设备牢固固定在运输平台或座架上直至搬迁到安装场地止。

危险: 设备在搬运和起吊的过程中, 按照正确的使用规范, 使用不当给设备造成损伤后, 现场很难修复, 必要时要运回公司进行修复工作, 返送及修理费则由贵公司负担。

Equipment Handling: Use complete transportation equipment for moving. Pay attention to the equipment's center of gravity during handling. Ensure the equipment is firmly secured to the transport platform or bracket until it is moved to the installation site.

Danger: During the handling and lifting of the equipment, follow the correct operating specifications. Damage caused by improper use is difficult to repair on-site. If necessary, the equipment must be shipped back to the company for repairs, and the shipping and repair costs shall be borne by your company.

1.2 运转时注意事项 Precautions During Operation

必须安排持有资格证书的专业人员进行电气设备的安装与维护, 并检查接地装置, 以避免任何使用该设备的人员受到惊吓、伤害和死亡的威胁。

在您对本设备进行调节、清洗、加润滑油和维修前, 始终要保持电源是关闭的状态。

在电气系统中, 不应该存在任何的改动或是添加。如有任何疑问改动请先联系我公司技术部门寻求解决方案。

Electrical equipment installation and maintenance must be conducted by qualified professionals. The grounding device must also be inspected to prevent electric shock, injury, or death to any personnel using the equipment.

Always ensure the power supply is turned off before adjusting, cleaning, lubricating, or maintaining the equipment.

No modifications or additions shall be made to the electrical system. If you have any questions or require modifications, contact our company's technical department first to obtain solutions.

注意:在运行设备时,请务必确认所有电气联动设备工作正常。

警告:运行设备前先检查。如未在运行前检查,可能导致设备的损伤或损坏。

Note: Before operating the equipment, always confirm that all electrical interlocking devices are functioning properly.

Warning: Inspect the equipment prior to operation. Failure to do so may cause damage to the equipment.



1.3 动态检重机概要 Overview of the Dynamic Checkweigher

以下是动态检重机图示与部件介绍:

The following is the dynamic checkweigher diagram and component introduction:

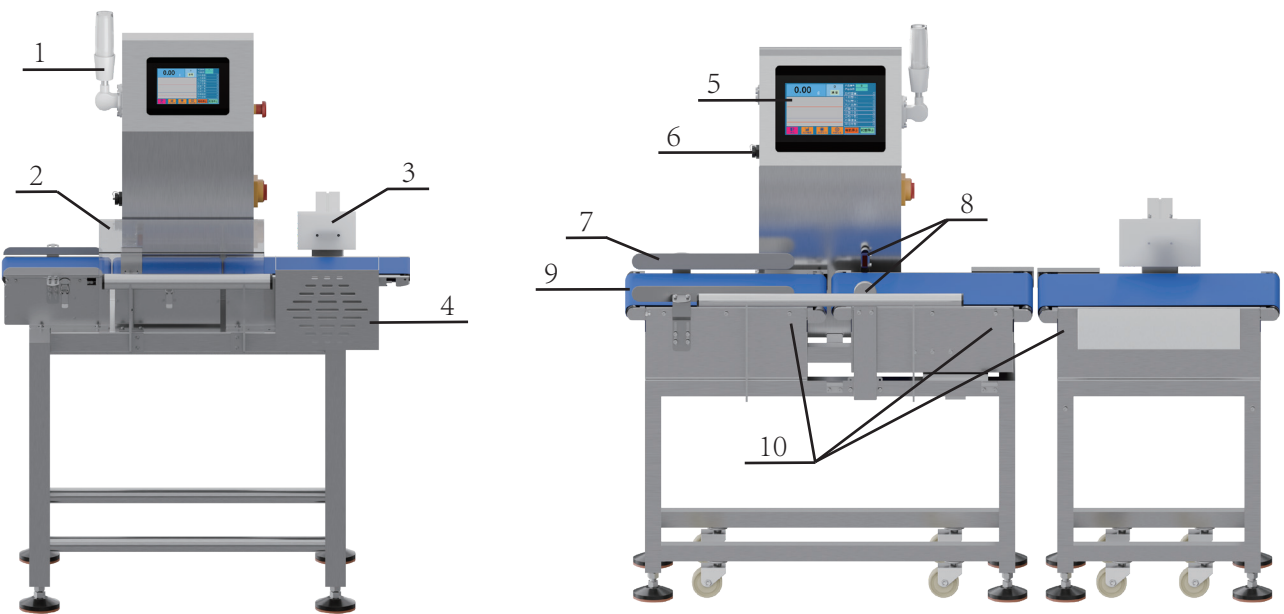

- 1.报警灯,产品合格亮绿灯、不合格亮红灯。
- 2.防风罩,用于遮挡外部产生的风力,保证精度。
- 3.剔除器,对不合格或指定产品进行剔除。
- 4.剔除收集器,收集被剔除的产品。
- 5.触摸屏,用于操作设备的运行状态和参数调整。
- 6.数据接口,导出或传输称重数据。
- 7.挡板,可根据物料的尺寸,调节宽度。
- 8.光电,检测产品位置、辅助计数和防误触等。
- 9.皮带,输送物料,使物料平稳的输送过秤。
- 10.电机位置,传动滚筒,带动皮带。

1. Alarm Light: Green for qualified products, red for unqualified.
2. Wind Shield: Blocks external wind to ensure accuracy.
3. Rejector: Rejects unqualified or designated products.
4. Rejected Collector: Collects rejected products.
5. Touch Screen: Controls equipment operation and parameter adjustment.
6. Data Interface: Exports or transmits weighing data.
7. Baffle: Width adjustable to material size.
8. Photoelectric Sensor: Detects product position, aids counting, prevents false triggers.
9. Conveyor Belt: Transports materials for smooth weighing.
10. Motor & Drive Roller: Drives the conveyor belt.

2. 安装事项 Installation Instructions

我们的动态检重机是高性价比、高可靠性的选择, 在高速度的条件下依旧能满足高精度测重需求。虽然检重秤人性化的结构设计使设备的安装变得非常简单, 但是建议您按以下步骤进行安装。

Our dynamic checkweigher is a cost-effective and highly reliable choice. It meets high-precision weighing requirements even under high-speed conditions.

Although the user-friendly structural design of the checkweigher makes installation very simple, we recommend following the steps below for installation.

2.1 技术参数 Technical Parameters

以下的动态检重机参数仅供参考, 具体技术参数请依据合同与实际数据。

The following dynamic checkweigher parameters are for reference only. For specific technical parameters, please refer to the contract and actual data.



数据仅供参考

Data for reference only

称重输送带宽50mm, 量程<100g, 精度 $\pm 0.05g$ 起, 输送速度20~60m/min
称重输送带宽100mm, 量程<500g, 精度 $\pm 0.1g$ 起, 输送速度20~60m/min
称重输送带宽150mm, 量程<1kg, 精度 $\pm 0.2g$ 起, 输送速度20~60m/min
称重输送带宽220mm, 量程<2kg, 精度 $\pm 0.3g$ 起, 输送速度20~80m/min
称重输送带宽300mm, 量程<3kg, 精度 $\pm 0.5g$ 起, 输送速度20~80m/min
称重输送带宽400mm, 量程<10kg, 精度 $\pm 2g$ 起, 输送速度20~60m/min
称重输送带宽500mm, 量程<30kg, 精度 $\pm 3g$ 起, 输送速度20~40m/min
称重输送带宽600mm, 量程<50kg, 精度 $\pm 5g$ 起, 输送速度20~35m/min

Weighing conveyor belt width: 50mm; Measuring range: <100g; Accuracy: $\pm 0.05g$ (starting from);
Conveying speed: 20~60m/min

Weighing conveyor belt width: 100mm; Measuring range: <500g; Accuracy: $\pm 0.1g$ (starting from);
Conveying speed: 20~60m/min

Weighing conveyor belt width: 150mm; Measuring range: <1kg; Accuracy: $\pm 0.2g$ (starting from);
Conveying speed: 20~60m/min

Weighing conveyor belt width: 220mm; Measuring range: <2kg; Accuracy: $\pm 0.3g$ (starting from);
Conveying speed: 20~80m/min

Weighing conveyor belt width: 300mm; Measuring range: <3kg; Accuracy: $\pm 0.5g$ (starting from);
Conveying speed: 20~80m/min

Weighing conveyor belt width: 400mm; Measuring range: <10kg; Accuracy: $\pm 2g$ (starting from);
Conveying speed: 20~60m/min

Weighing conveyor belt width: 500mm; Measuring range: <30kg; Accuracy: $\pm 3g$ (starting from);
Conveying speed: 20~40m/min

Weighing conveyor belt width: 600mm; Measuring range: <50kg; Accuracy: $\pm 5g$ (starting from);
Conveying speed: 20~35m/min

2.2 安装前检查 Pre-Installation Inspection

当您拥有一台新的动态检重机时,建议您按以下步骤对设备进行检查。

- 检查是否存在运输造成的损坏,如果发现包装木箱严重破损,应联系厂家立即更换设备。
- 检查整机,如果发现设备外部破损,设备工作不正常,或未能通过性能测试,请和我公司售后服务部门联系。
- 如果因运输造成设备的损坏,请注意保留包装,通知运输部门和我公司售后服务部,售后服务部会安排维修或更换。

When you receive a new dynamic checkweigher, we recommend inspecting the equipment following the steps below.

- Check for damage caused during transportation. If severe damage to the wooden packaging box is found, contact the manufacturer to replace the equipment immediately.
- Inspect the entire machine. If external damage, abnormal operation, or failure to pass performance tests is detected, contact our after-sales service department.
- If the equipment is damaged due to transportation, keep the packaging intact, notify the transportation company and our after-sales service department. The after-sales service department will arrange for repair or replacement.

2.3 安装环境 Installation Environment

- 电源电压浮动不超过 $\pm 10\%$ 。Power supply voltage fluctuation shall not exceed $\pm 10\%$.
- 无高功率高频开关的场所。Locations free of high-power and high-frequency switches.
- 无挥发性的易燃物、腐蚀性气体的场所。Locations without volatile flammables or corrosive gases.
- 无地面振动的场所。Locations free of ground vibration.
- 附近无高温发热器的场所。Locations without high-temperature heaters nearby.

2.4 注意事项 Precautions

- 为了在运输过程中不损坏传感器,出厂时可能采用称重传输带和重量传感器分开。安装称重传输带时要轻拿轻放,勿损坏重量传感器。电源应和产生噪声的其它设备的供电系统严格分开(如变频器、频繁启停的动力设备等)。
- 本设备与其它设备(前,后段传送带等)连接时,应严格按CE\UL电气规范布线、配电;并且本设备需单独接地。
- To avoid damaging the load cell during transportation, the weighing conveyor belt and load cell may be shipped separately from the factory. When installing the weighing conveyor belt, handle it with care to prevent damage to the load cell. The power supply must be strictly separated from the power supply systems of other noise-generating equipment (such as frequency converters, power equipment with frequent start-stop operations, etc.).

- When connecting this equipment to other devices (such as front and rear section conveyors), wiring and power distribution must comply strictly with CE/UL electrical standards. Additionally, this equipment requires an independent ground connection.

2.5 传送带的安装 Installation Environment

- 旋转调节螺母, 将从动轴与主动轴的距离调到最小;
- 检查皮带的运行方向, 按(图一)粗箭头方向将皮带套入托盘;
- 调节托盘两边的调节螺母, 使皮带的张紧度适度. 并使皮带置于托盘的中心位置(如图二)。

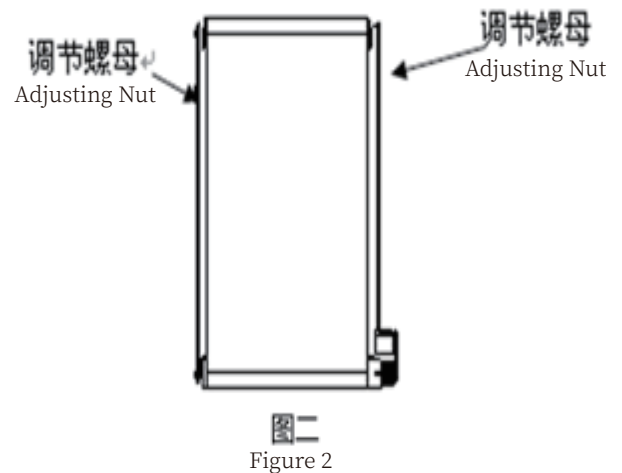
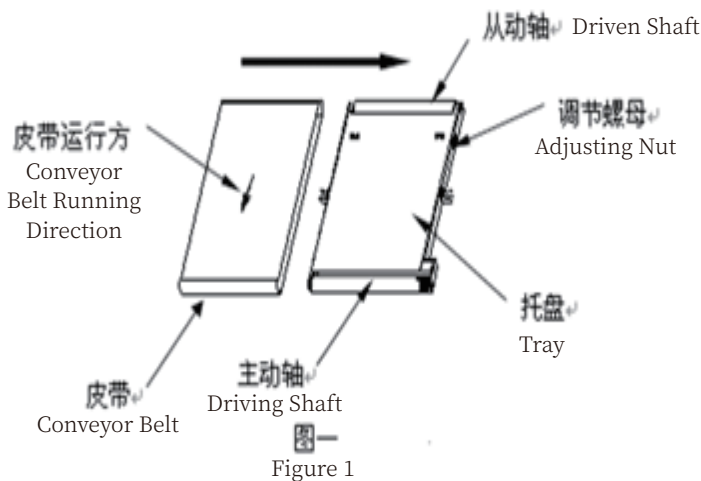

- Rotate the adjusting nuts to minimize the distance between the driven shaft and the driving shaft.
- Check the running direction of the conveyor belt, and fit the belt onto the tray according to the direction of the thick arrow in (Figure 1).
- Adjust the adjusting nuts on both sides of the tray to achieve proper belt tension, and center the belt on the tray (as shown in Figure 2).

2.6 传送带的调整 Adjustment of the Conveyor Belt

- 将皮带张紧度调整到适度, 放到机子上运行, 观察皮带运行情况;
- 如果皮带在托盘中间, 属正常状态, 不用做任何调节;
- 如果皮带往左偏, 可进行如下调整:
 1. 可“调紧”左边调节螺母, 需渐进式调整. 边调整边观察, 直到皮带回到中心位置为准. 若发现调节螺母已很紧, 请勿强行调整。
 2. 可“调松”右边调节螺母, 需渐进式调整. 边调整边观察, 直到皮带回到中心位置为准。
 3. 若偏离比较大, 渐进式调整难以回到中心位置时, 可先迅速调松右边的皮带。
 4. 如果皮带已经与侧面挡板有磨擦应立即停机检查。
 5. 皮带安装完后, 会有一定的延伸, 在有一定的程度张力的状态下, 让皮带转动1-2周, 是皮带全周均匀, 准确固定张紧轮, 在运行40小时后, 在重新调整、固定张紧轮, 此时皮带的中间层骨架材料已完全伸展均匀, 将不

会再有延伸。

- Adjust the conveyor belt to proper tension, place it on the machine for operation, and observe its running condition.
- If the belt stays centered on the tray, it is in normal status—no adjustment is needed.
- If the belt deviates to the left, perform the following adjustments:
 1. Tighten the left adjusting nut gradually. Keep observing while adjusting until the belt returns to the center. Do not force adjustment if the nut is already fully tight.
 2. Loosen the right adjusting nut gradually. Keep observing while adjusting until the belt returns to the center.
 3. If the deviation is significant and gradual adjustment fails to center the belt, quickly loosen the right side of the belt first.
 4. Stop the machine immediately for inspection if the belt rubs against the side baffles.
 5. The belt will stretch slightly after installation. With appropriate tension, let the belt rotate 1-2 full cycles to ensure uniform tension around its entire length, then secure the tension pulley firmly. After 40 hours of operation, readjust and resecure the tension pulley—by this time, the core framework material of the belt will have fully and evenly stretched, preventing further elongation.

3. 用户指南 User Guide

向用户提供简单而功能明晰的控制面板, 以进行基本的操作。

动态检重机的操作过程由电源开关、电机开关和工业触摸屏等组合完成。通过电源开关控制设备的电源。

其它功能可由工业触摸屏控制, 通过它, 您可以进入不同的功能菜单或直接获得特定的功能应用。熟悉了本章的内容, 可以使用本设备进行基本操作。

A simple and functionally clear control panel is provided for basic operations.

The operation of the dynamic checkweigher is completed through a combination of the power switch, motor switch, industrial touch screen, etc. The power switch controls the equipment's power supply. Other functions can be controlled via the industrial touch screen—through it, you can access different function menus or directly use specific functions.

After familiarizing yourself with the content of this chapter, you will be able to perform basic operations of the equipment.

3.1 触摸屏主界面 Touch Screen Main Interface

开机后显示屏上提示语言选择对话框, 客户可根据需要选择所需要的语言, 默认以中文方式进入, 进入系统后主界面菜单如图3.1所示。

After powering on, a language selection dialog box will appear on the display. You can choose the desired language as needed. The system defaults to Chinese. After entering the system, the main interface menu is shown in Figure 3.1.



(图3.1-运行主界面)

(Figure 3.1 - Operation Main Interface)

- 电机启停: 控制检重称皮带运转开启或停止。(无此按键是外部开关手动操作)
- 检重启动: 点击此按钮后显示“检重运行”开始检测, 再次点击停止检测, 当处于检重状态时, “标定、报表统计、参数设置界面”按钮处于灰色状态, 无法进行编辑。
- 标定: 在初始使用时, 需要对秤台进行校正。
- 数据统计: 查看检测详细报表。
- 参数设置: 对设备参数进行修改或设置。
- Motor Start/Stop: Controls the operation start or stop of the checkweigher belt. (If this button is not available, operate manually via an external switch.)
- Weighing Start: Click this button to display "Weighing in Progress" and start detection; click again to stop. When in weighing mode, the "Calibration", "Report Statistics", and "Parameter Settings Interface" buttons will be grayed out and unavailable for editing.
- Calibration: Calibrate the weighing platform when using the equipment for the first time.
- Data Statistics: View detailed detection reports.
- Parameter Settings: Modify or configure equipment parameters.

3.2 功能检查 Function Check

- 接通设备电源和气源, 电源的供电电压为交流220V±10%, 频率为50HZ。打开电源开关。接通5-7kg/cm²的压缩气源(注意高压阀气源方向)。
- 将称台上不需要的物体清理干净, 在主界面的左上方(箭头指示)有重量显示, 点击“清零”按钮, 使显示处于零点状态, 再将砝码放在秤台中央, 查看显示屏显示的重量值与砝码重量是否相符, 拿开砝码后显示窗口是否归零(如下图所示), 如果显示值与砝码重量不相符请按本手册第4.1条进行标定。
- Connect the equipment to the power supply and air source. The power supply voltage shall be AC 220V ±10% with a frequency of 50Hz. Turn on the power switch. Connect a horizontal pressure air source of 5-7kg/cm² (note the direction of the high-pressure valve air source).
- Remove any unnecessary objects from the weighing platform. The weight display is located at the top left of the main interface (as indicated by the arrow). Click the "Zero" button to set the display to zero. Then place weights in the center of the weighing platform and check if the displayed weight matches the weight of the weights. Verify if the display returns to zero after removing the weights (as shown in the figure below). If the displayed value does not match the weight of the weights, calibrate the equipment according to Section 4.1 of this manual.



(图3.2-运行清零)

(Figure 3.2 - Operation Zero Reset)

4.参数设置 Parameter Settings

4.1 标定 Calibration

当静态称重出现偏差时, 需要校正。

- 主界面点击“标定”按钮。
- 点击“标定”按钮, 出现标定界面。
- 点击“零点标定”等待“标定信息栏”显示零点标定成功。
- 将标准砝码置入秤台中央、待显示稳定后, 输入砝码的重量。
- 点击“量程标定”按钮等待“标定信息栏”显示量程标定成功, 此时标定成功, 点击“返回”按返回主界面。

Calibration is required when there is a deviation in static weighing.

- On the main interface , click the "Calibration" button.
- After clicking the "Calibration" button, the calibration interface will appear .
- Click "Zero Calibration" and wait for the "Calibration Information Bar" to display "Zero Calibration Successful".
- Place standard weights in the center of the weighing platform. After the display stabilizes, enter the weight of the weights.
- Click the "Range Calibration" button and wait for the "Calibration Information Bar" to display "Range Calibration Successful". Calibration is now complete. Click the "Return" button to go back to the main interface.

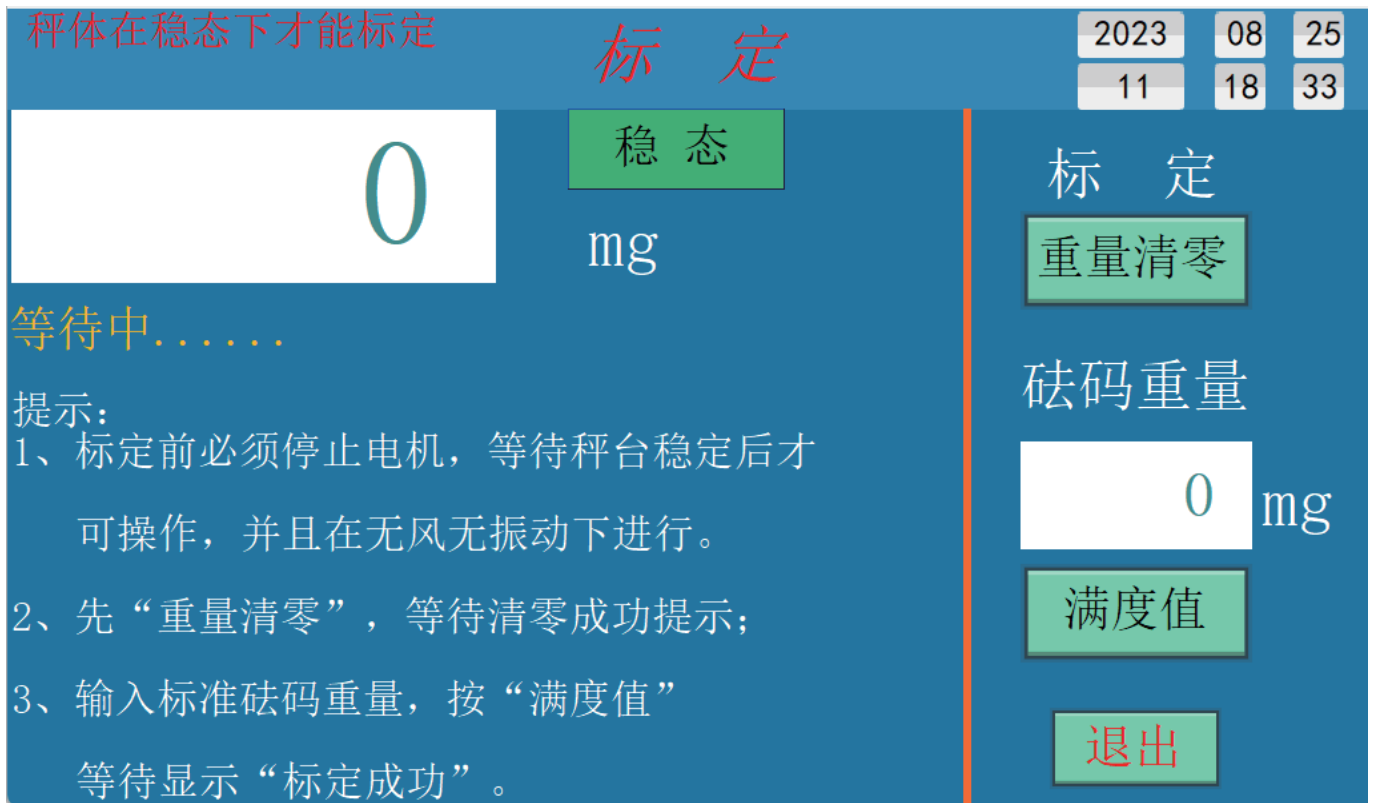

(图4.1-标定界面)

(Figure 4.1 - Calibration Interface)

4.2 用户登录 Parameter Settings Login Operation

- 在主界面(图3.1)点击“参数设置”按钮进入登录密码界面(图4.2)。
- 用户登录界面分三个等级, 点击下拉箭头可选择相对应的用户(管理员、工厂调试), 其中客户只需用到一种(管理员): 管理员的密码都为: “888”。
- 用户密码栏内输入密码后点击“确认”进入下一步操作。

以管理员身份登录时可操作的选项有“参数设置”进行机器相关的参数设置。

- On the main interface (Figure 3 .1), click the "Parameter Settings" button to enter the login interface (Figure4.2).
 - The user login interface has three levels. Click the drop-down arrow to select the corresponding user (Administrator, Factory Debugging). Customers only need to use one level: Administrator. The default password for the Administrator is "888".
 - Enter the password in the user password field and click "Confirm" to proceed to the next step.
- When logging in as an Administrator, the available option is "Parameter Settings" for configuring relevant machine parameters .



(图4.2-登录密码界面)

(Figure 4.2 - Login Password Interface)

4.3 参数设置 Parameter Settings

- 在主界面(图3.1)点击“参数设置”按钮进入登录界面。
- 管理员身份进入系统后,点击“配方参数”按钮弹出参数设置界面(图4.3.1)。

参数另存为 0		参数设置		2023	08	25
				11	19	53
产品编号	0	2次滤波	0	切换参数 ↑ 00 ↓ 功能参数 保存参数 退出		
产品名称		滤波系数	0			
目标重量	0	皮带速度	0			
上限偏差	0	不合格延时	0.00			
下限偏差	0	保持时间	0.00			
纠正重量	0	合格延时	0.00			
光电延时	0.00	保持时间	0.00			
采样个数	0	零范围阈值	0			

(图4.3.1-参数设置界面)

(Figure 4.3.1 - Parameter Settings Interface)

- 1.皮带速度:皮带在运行时,实际皮带运行的距离(按秒/米)。
- 2.滤波系数:数字越大,滤波越重,越平稳,但响应变慢(推荐“3”)。
- 3.二次滤波系数:用来抑制物体上秤台引起的过冲,此参数越大抗震效果越好(推荐“2”)。
- 4.动态范围:大重量和小重量切换检重时需要修改,此值越大越容易进入稳态,物体越轻设定越小。(推荐“8”)。
- 5.动态时间:物体在秤台上有效称重时间的30% ~ 70% 有效称重时间 = (秤台长-物体长)/皮带速度 (推荐“0.05”)。
- 6.检重延时时间:在物体触发光电时,延时时间保证物体完全在秤台上(在单光电模式下可以使用。)(推荐“0.25—0.35”)。
- 7.检测数据个数:物体在秤台上,抓取足够的数字。(推荐“30”)。
- 8.上限重量:重量区间范围的最大值(大于下限)。
- 9.下限重量:重量区间范围的最小值(小于上限)。
- 10.纠正重量:使显示重量与实际重量相符。(实际重量=显示重量+纠正重量)
- 11.剔除延时:当物体出秤台后到拨杆出来的时间,保证拨杆可以完全的将物体剔除出去(皮带速度的变化,时间也会变化)
- 12.剔除实践:是指当拨杆弹出时,停止多久时间再回去(保证物体完全进入拨杆的范围,确保物体正确排出)



(图4.3.2-参数设置界面)

(Figure 4.3.2 - Parameter Settings Interface)

13.自动学习,首先在运行界面,点击电机启动,再把学习重量改成和目标重量的数据一致。

14.点击开始学习,按照指令拿同一件产品学习10次,学习完成后,如果称重结果不理想,可调光电位置,向前调一点数据或向后调一点数据,把数据调好,点退出即可。

15.自动学习退出后,点击检重称重,就进行运行称重。



(图4.3.3-统计报表界面)

(Figure 4.3.3 - Statistical Report Interface)

16.主界面进入“数据报表”。

17.数据报表中记录当前重量范围和当天班次生产的记录,检重个数和总的个数、重量。

18.在“详细报表”中可以在插U盘的情况下,记录所有生产物体的具体日期、时间和单个重量,每个重量区间。

A	B	C	D	E	F	G	H	I
Date	Time	配方号	配方名	目标量	下限	上限	检重值	检重结果
2013/10/17	17:16:14	3		1648	5	5	1646	0
2013/10/17	17:16:19	3		1648	5	5	1647	0
2013/10/17	17:16:23	3		1648	5	5	1644	0
2013/10/17	17:16:36	3		1648	5	5	1648	0
2013/10/17	17:16:41	3		1648	5	5	1652	0
2013/10/17	17:16:45	3		1648	5	5	1647	0
2013/10/17	17:16:49	3		1648	5	5	1641	1
2013/10/17	17:17:16	3		1648	5	5	1647	0
2013/10/17	17:17:20	3		1648	5	5	1647	0
2013/10/17	17:17:24	3		1648	5	5	1637	1
2013/10/17	17:17:29	3		1648	5	5	1642	1
2013/10/17	17:17:33	3		1648	5	5	1651	0
2013/10/17	17:17:38	3		1648	5	5	1645	0
2013/10/17	17:17:42	3		1648	5	5	1648	0
2013/10/17	17:17:47	3		1648	5	5	1646	0
2013/10/17	17:17:51	3		1648	5	5	1642	1

(图4.3.4-导出的详细报表)

(Figure 4.3.4 - Exported Detailed Report)

- On the main interface (Figure 3.1), click the "Parameter Settings" button to enter the login interface.
 - After logging into the system as an Administrator, click the "Recipe Parameters" button to bring up the parameter settings interface (Figure 4.3.1).
1. Sorting Speed: The actual running distance of the belt during operation (unit: meters per second).
 2. Filter Coefficient: A larger value means stronger filtering and more stable performance, but slower response (recommended value: "3").
 3. Secondary Filter Coefficient: Used to suppress overshoot caused by objects entering the weighing platform. A larger value provides better shock resistance (recommended value: "2").
 4. Dynamic Range: Needs modification when switching between heavy and light weight weighing. A larger value allows easier entry into a stable state; set a smaller value for lighter objects (recommended value: "8").
 5. Dynamic Time: 30% ~ 70% of the effective weighing time of an object on the platform. Effective weighing time = (length of weighing platform - length of object) / belt speed (recommended value: "0.05").
 6. Weighing Delay Time: When an object triggers the photoelectric sensor, this delay ensures the

object is fully on the weighing platform (applicable in single photoelectric mode) (recommended range: "0.25—0.35").

7. Number of Detection Data Points: Captures sufficient data points while the object is on the weighing platform (recommended value: "30").

8. Upper Limit Weight: The maximum value of the weight range (greater than the lower limit).

9. Lower Limit Weight: The minimum value of the weight range (less than the upper limit).

10. Correction Weight: Adjusts the displayed weight to match the actual weight (Actual weight = Displayed weight + Correction weight).

11. Rejection Delay: The time from when the object leaves the weighing platform to when the lever is activated, ensuring the lever can fully reject the object (varies with belt speed).

12. Rejection Duration: The time the lever remains extended before retracting (ensures the object fully enters the lever's range for correct discharge).

13. Auto Learning: First, on the operation interface, click "Motor Start", then set the learning weight to match the target weight .

14. Click "Start Learning" and follow the instructions to learn with the same product 10 times. If the weighing result is unsatisfactory, adjust the photoelectric sensor position (slightly forward or backward), set the data correctly, and click "Exit".

15. After exiting Auto Learning, click "Weighing Start" to begin operational weighing.

16. Access "Data Report" from the main interface.

17. The Data Report records the current weight range, shift production records of the day, number of weighed items, total quantity, and total weight.

18. In the "Detailed Report", when a USB drive is inserted, all production data is recorded, including the specific date, time, individual weight, and weight range of each object.

5.维护保养 Maintenance

5.1 日常维护 Daily Maintenance

作业前的基本检查:

- 确认所有传送带之间是否接触在一起。
- 确认标准值、上限、下限值的设定是否正确。
- 用一件实测产品手动重复测试10次以上, 确认其精度是否稳定。
- 一件不合格产品检测剔除装置是否正常。

日常注意事项:

- 输送带是否有开裂。
- 输送带有无转偏, 如有转偏应调节两边的调节装置, 直到皮带无转偏为止; 输送带在运行状态中是否有异音。
- 不要用力压称重段, 防止传感器压坏。

Pre-Operation Basic Checks

- Confirm that all conveyors are properly connected.
- Verify the correct setting of standard values, upper limit values, and lower limit values.
- Manually test with an actual product repeatedly for more than 10 times to confirm stable accuracy.
- Check if the rejection device for unqualified products operates normally.

Daily Precautions

- Inspect the conveyor belt for cracks.
- Check if the conveyor belt is misaligned. If misaligned, adjust the adjusting devices on both sides until the belt runs straight. Listen for abnormal noises during the conveyor's operation.
- Do not press hard on the weighing section to avoid damaging the sensor.

5.2 设备清洁 Equipment Cleaning

- 在清洁设备之前切记断开电源。
- 可拆卸输送带可用消毒剂或约60°C的温水清洗。
- 可将输送带放在沸水中浸泡5分钟, 或用次氯酸水溶液(200ppm)浸泡(3分钟以内)后再用水洗净。不管上述哪一种方法, 请务必将洗净后的输送带充分沥干, 再安装到传送带上。防止霉变现象。
- 定期对皮带表面及滚筒表面进行清洗, 可使用酒精或中性洗衣粉, 洗完再用清水冲净, 严禁使用纯苯类化学物品擦拭皮带。
- Remember to disconnect the power supply before cleaning the equipment.
- Removable conveyor belts can be cleaned with disinfectant or warm water at approximately 60°C.
- The conveyor belt can be soaked in boiling water for 5 minutes, or immersed in a hypochlorous acid aqueous solution (200ppm) for no more than 3 minutes, then rinsed with clean water. Regardless of the method used, the cleaned conveyor belt must be fully drained before reinstalling it to prevent mold growth.
- Regularly clean the surface of the belt and rollers. Alcohol or neutral laundry detergent can be used, followed by rinsing with clean water. Never use pure benzene-based chemicals to wipe the belt.

5.3 故障处理 Troubleshooting

- 基本故障排除:
 1. 是否按照说明书进行正确的设定。
 2. 插件是否有接触不良。
 3. 有无电线、配线类的断线或脱线。
 4. 螺丝、零部件类是否有脱落或松动。

5.设备的零部件有无破损、烧损、异常发热、变色、变形以及磨损。

6.无导致障碍的铁锈或污垢。

- 为了检查而拆卸的接插件、零部件类, 在检查完毕后请重新正确复位。
- 急剧的环境变化雷电或异常电压等导致的电源异常、冲击以及不是正常使用中所导致的直接事故原因时, 须进行综合检查。
- 设备在搬运的过程中, 可能造成电器件插头的松动和脱落, 机械受外力的挤压而变形在使用前需认真检查, 确无异常再通电运行。

故障现象	分析	判定方法
显示屏无显示	1、电源问题。 2、漏电过载保护, 有无跳闸。 3、长期存放。	1、电源线头是否脱落。 2、有无漏电和短路。 3、定期通电测试。
皮带不转动	1、阻力太大, 电机过热保护。 2、线路短路。 3、电源不稳定。 4、皮带打滑。 5、变频器通讯不上。 6、未设定速度。 7、速比系数未设定。	1、减少电机运转时阻力。 2、检查线路。 3、使用稳压器。 4、皮带调整螺丝没有调整到位, 皮带是松散状态。 5、重新拔插通讯插头更换新的通讯线。 6、参数设置设定检重速度。 7、重新设置速比系数。
无重量显示	1、传感器的保护装置。 2、通讯不上(数字显示框没显示)。 3、传感器损坏(无法标定的情况下)。	1、拆除保护片(出货前保护传感器)。 2、检查接近模块的通讯线是否松动。 3、确定没有数字跳动, 又无法标定。没有任何外界的东西碰到。
显示重量与实际不准确	1、因外界振动和风力过大造成。 2、物料尺寸不能大于秤台长度。 3、光电检测的延时不准确。 4、实时重量在无物体时在零点。 5、参数的设置, 是否正确。	1、环境必须是无风、无振动才能确保称重时精度。 2、物料最大尺寸是秤台的三分之二。 3、在参数设置修改采样延时, 加/减少时间。 4、保证机器运行时, 实时重量显示一直在零点状态。 5、基本的滤波系数是否设置正确。
剔除不动作	1、气压是否正确。 2、摆杆动作是否正常。 3、电磁阀是否工作正常。 4、剔除的时间设置。	1、检查气源处理器有无气压进入。 2、摆杆的传动结构是否有螺丝松动。 3、电磁阀和固态继电器的电压输入、输出是否正确。 4、在参数设置里, 剔除时间, 不能为0, 否则不动作。
皮带跑偏	1、两边的调整螺丝松动 2、物体运动时, 总向一边运动。	1、拧紧左右两边的调整螺丝。 2、在设备的进料端, 调整物体进入机器的位置。

- Basic Troubleshooting:

1. Verify if the settings are correctly configured in accordance with the instruction manual.
 2. Check for poor contact of connectors.
 3. Inspect for broken or disconnected wires and cables.
 4. Examine if screws and components are loose or detached.
 5. Inspect if the equipment's components are damaged, burned out, abnormally heated, discolored, deformed, or worn.
 6. Ensure there is no rust or dirt that could cause malfunctions.
- After inspection, correctly reinstall and reset all connectors and components that were removed for checking.
 - Conduct a comprehensive inspection if there are power abnormalities, impacts caused by sudden environmental changes, lightning, abnormal voltage, or other direct accident causes not related to normal use.
 - During equipment transportation, electrical plugs may loosen or fall off, and mechanical parts may deform due to external pressure. Conduct a thorough inspection before use, and only power on the equipment if no abnormalities are found.

Fault

Phenomena	Analysis	Judgment Methods
No display on the screen	1, Power supply issues. 2, Leakage and overload protection: Check if the circuit breaker has tripped. 3, Long-term storage (related impact).	1, Check if the power cord connector is loose or detached. 2, Inspect for electric leakage and short circuits. 3, Conduct regular power-on tests.

Fault

Phenomena

Conveyor belt fails to rotate

Analysis

- 1, Excessive resistance triggering the motor's overheat protection.
- 2, Circuit short circuit.
- 3, Unstable power supply.
- 4, Conveyor belt slipping.
- 5, Inability to communicate with the frequency converter.
- 6, No speed set.
- 7, Gear ratio coefficient not set.

Judgment Methods

- 1, Reduce the resistance during motor operation.
- 2, Inspect the circuit wiring.
- 3, Use a voltage stabilizer.
- 4, Adjust the conveyor belt tensioning screws properly (the belt is loose if not adjusted in place).
- 5, Reconnect the communication connector or replace it with a new communication cable.
- 6, Set the checkweighing speed in the parameter settings.
- 7, Reset the gear ratio coefficient.

No weight display

- 1, The sensor's protective device (check if it is activated or improperly installed).
- 2, Communication failure (no display in the digital display box).
- 3, Sensor damage (in case of failure to calibrate).

- 1, Remove the protective sheet (installed to protect the sensor before shipment).
- 2, Check if the communication cable of the proximity module is loose.
- 3, Confirm there is no digital fluctuation, calibration failure, and no external objects are in contact with the sensor.

Displayed weight does not match the actual weight

- 1, Caused by excessive external vibration or wind.
- 2, Ensure the material size does not exceed the scale platform length.
- 3, Inaccurate delay of the photoelectric detection.
- 4, Check if the real-time weight is at zero when there is no object on the scale.
- 5, Verify if the parameters are set correctly.

- 1, Ensure the environment is windless and vibration-free to guarantee weighing accuracy.
- 2, The maximum material size shall not exceed two-thirds of the scale platform length.
- 3, Modify the sampling delay in parameter settings by increasing or decreasing the time.
- 4, Ensure the real-time weight display remains at zero during the machine's operation when no object is on the scale.
- 5, Verify if the basic filter coefficient is set correctly.

Fault

Phenomena

Rejection mechanism fails to operate

Analysis

- 1, Check if the air pressure is correct.
- 2, Verify if the swing rod operates normally.
- 3, Inspect if the solenoid valve is functioning properly.
- 4, Check the rejection time setting.

Judgment Methods

- 1, Check if there is air pressure entering the air source treatment unit.
- 2, Inspect if the screws of the swing rod's transmission structure are loose.
- 3, Verify if the voltage input and output of the solenoid valve and solid-state relay are correct.
- 4, In the parameter settings, the rejection time shall not be zero—otherwise, the rejection mechanism will fail to operate.

Conveyor belt deviation

- 1, Loose adjusting screws on both sides of the conveyor belt.
- 2, The object consistently moves to one side during transportation.

- 1, Tighten the adjusting screws on both the left and right sides of the conveyor belt.
- 2, Adjust the position of the object entering the machine at the feeding end of the equipment.

6. 电路图 Circuit Diagram

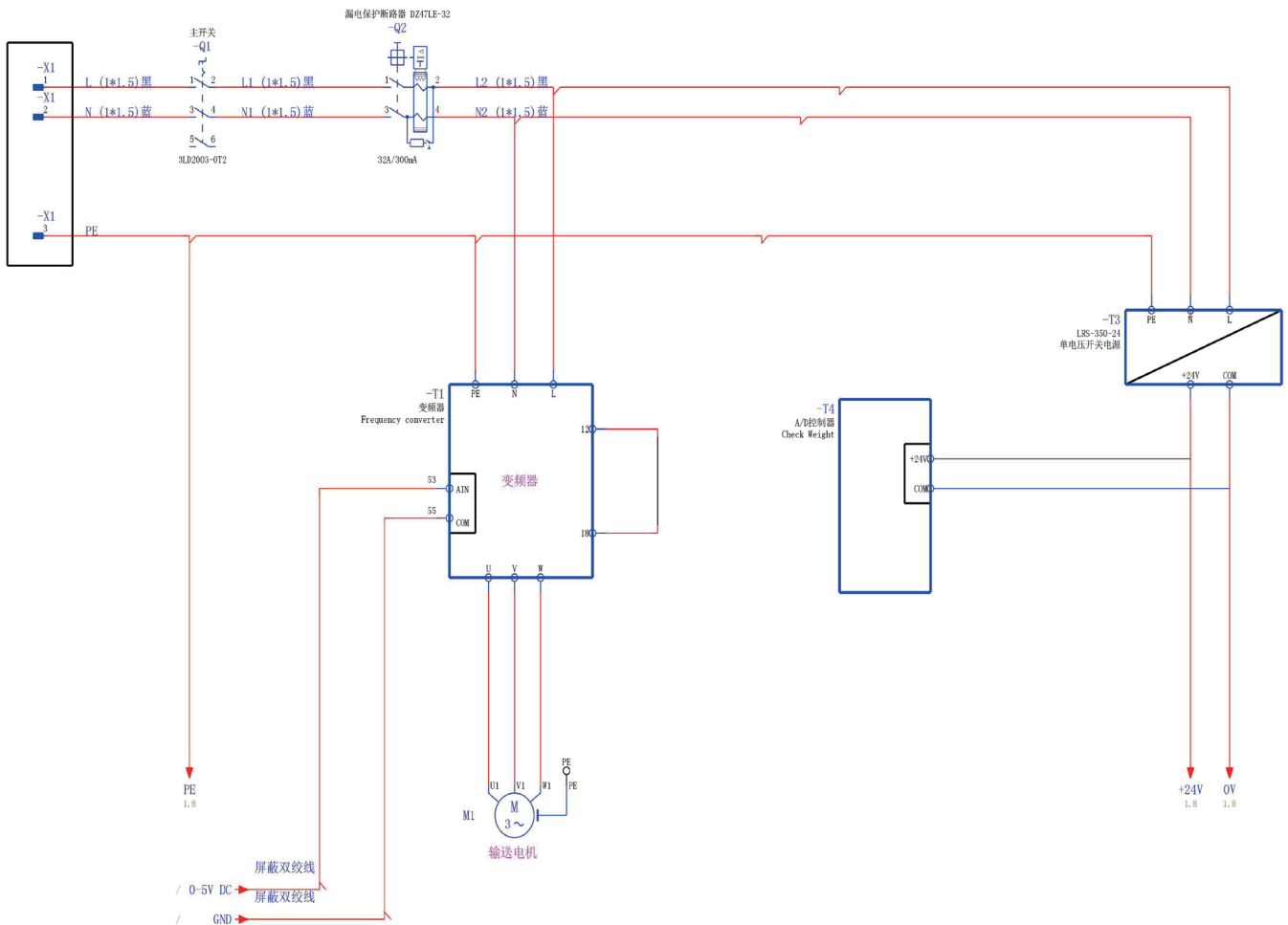

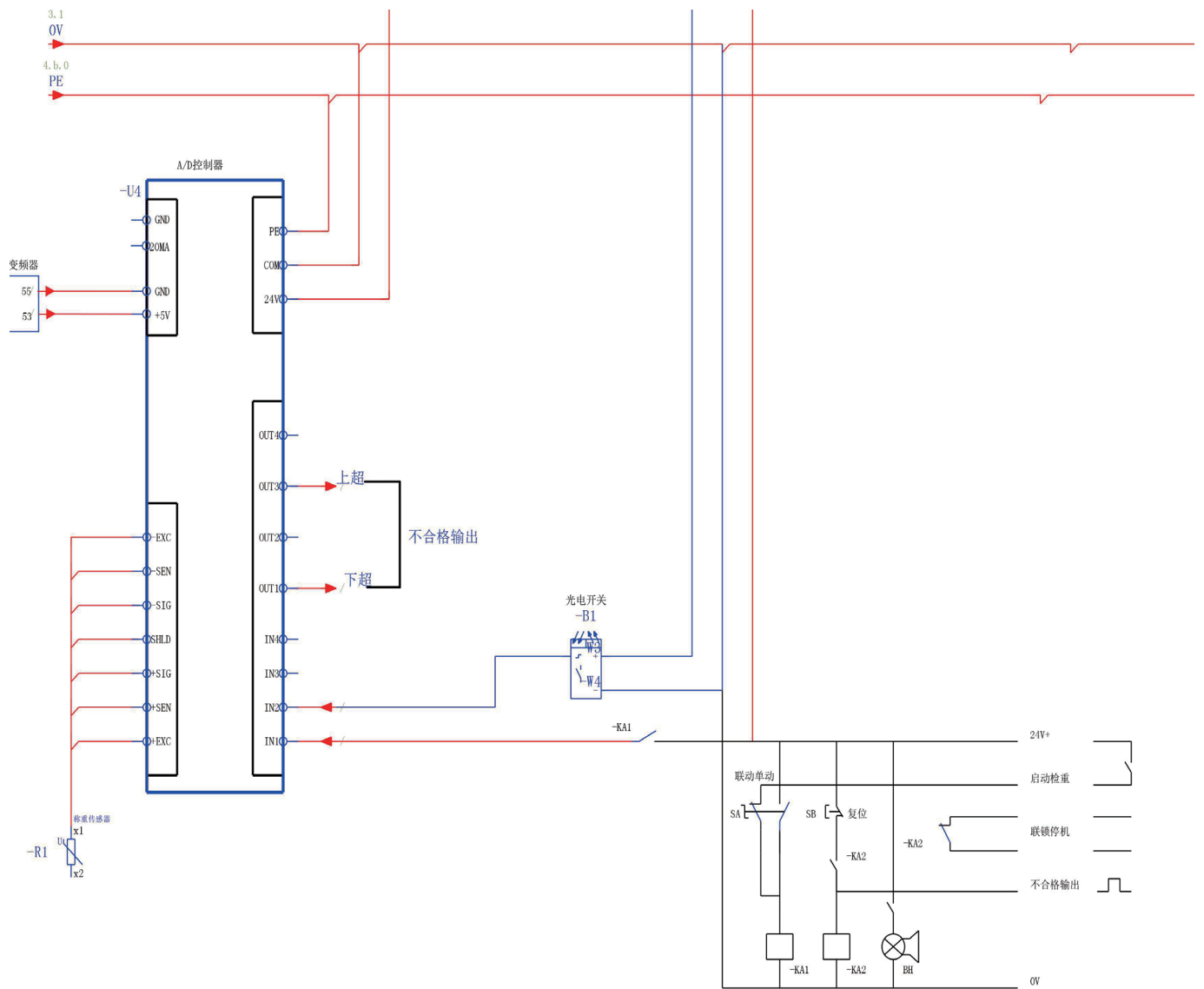

HMI MT6103ip

