



Features

- Interdigitated amplifying gates
- Fast turn-on and high di/dt
- Low switching losses

Typical Applications

- Inductive heating
- Electronic welders
- Self-commutated inverters

$I_{T(AV)}$ 800A
 V_{DRM}/V_{RRM} 1200~1800V
 t_q 16~35 μ s
 I_{TSM} 12 kA
 I^2t 720 10³A²S

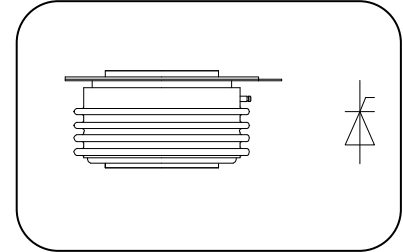

SYMBOL	CHARACTERISTIC	TEST CONDITIONS	$T_j(^{\circ}C)$	VALUE			UNIT
				Min	Type	Max	
$I_{T(AV)}$	Mean on-state current	180° half sine wave 50Hz Double side cooled, $T_c=55^{\circ}C$	125		800	1220	A
V_{DRM} V_{RRM}	Repetitive peak off-state voltage Repetitive peak reverse voltage	$V_{DRM} \& V_{RRM}$, $t_p=10ms$ $V_{DSM} \& V_{RSM} = V_{DRM} \& V_{RRM} + 100V$	125	1200		1800	V
I_{DRM} I_{RRM}	Repetitive peak current	$V_D = V_{DRM}$ $V_R = V_{RRM}$	125			60	mA
I_{TSM}	Surge on-state current	10ms half sine wave	125			12	kA
I^2t	I^2T for fusing coordination	$V_R = 0.6V_{RRM}$	125			720	A ² s*10 ³
V_{TO}	Threshold voltage		125			1.32	V
r_T	On-state slop resistance		125			0.36	m Ω
V_{TM}	Peak on-state voltage	$I_{TM}=2400A$, $F=21kN$	25			3.15	V
dv/dt	Critical rate of rise of off-state voltage	$V_{DM}=0.67V_{DRM}$	125			1000	V/ μ s
di/dt	Critical rate of rise of on-state current	$V_{DM}=67\%V_{DRM}$ $I_{TM}=(2-3)I_{T(AV)}$, $t=5s$ Gate pulse $t_r \leq 0.5\mu s$ $I_{GM}=1.5A$ $f=50Hz$	125			600	A/ μ s
Q_{rr}	Recovery charge	$I_{TM}=1000A$, $t_p=1000\mu s$, $di/dt=-20A/\mu s$, $V_R=100V$	125		650		μC
t_q	Circuit commutated turn-off time	$I_{TM}=1000A$, $t_p=1000\mu s$, $V_R=100V$ $dv/dt=30V/\mu s$, $di/dt=-20A/\mu s$	125	16		35	μs
I_{GT}	Gate trigger current		25	40		200	mA
V_{GT}	Gate trigger voltage	$V_A=12V$, $I_A=1A$		0.9		2.5	V
I_H	Holding current			20		300	mA
V_{GD}	Non-trigger gate voltage	$V_{DM}=67\%V_{DRM}$	125			0.3	V
$R_{th(j-c)}$	Thermal resistance Junction to case	At 180° sine double side cooled Clamping force 21kN				0.024	$^{\circ}C/W$
$R_{th(c-h)}$	Thermal resistance case to heat sink					0.006	
F_m	Mounting force			18		25	kN
T_{stg}	Stored temperature			-40		140	$^{\circ}C$
W_t	Weight			400			g
Outline	KT50cT						

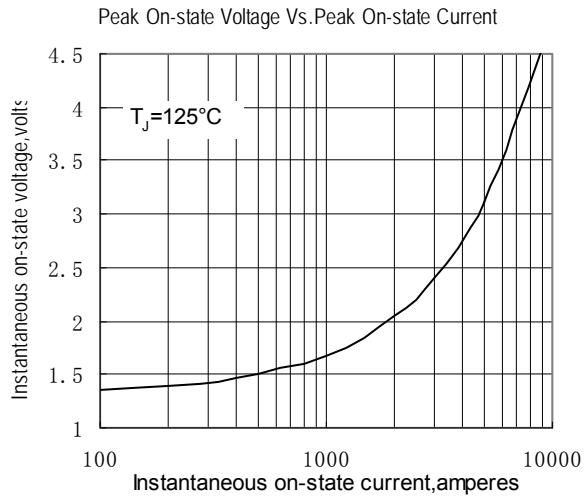

Fig.1

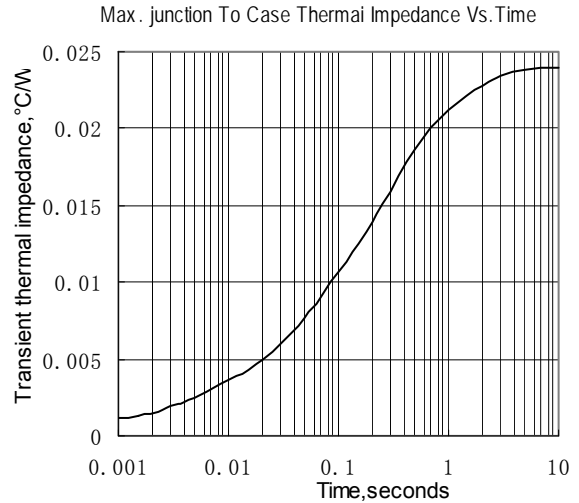

Fig.2

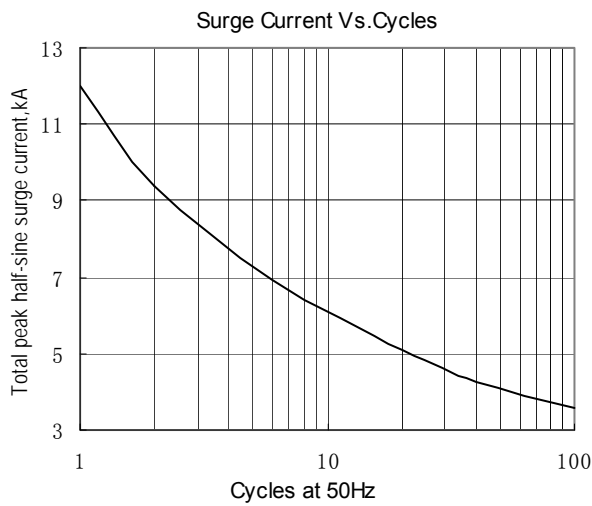

Fig.3

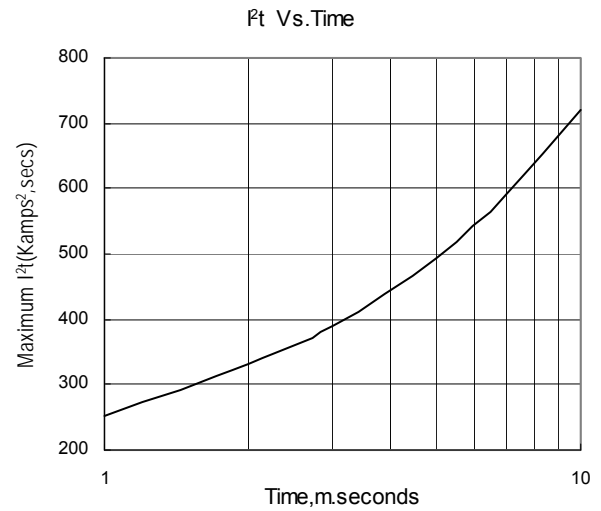

Fig.4

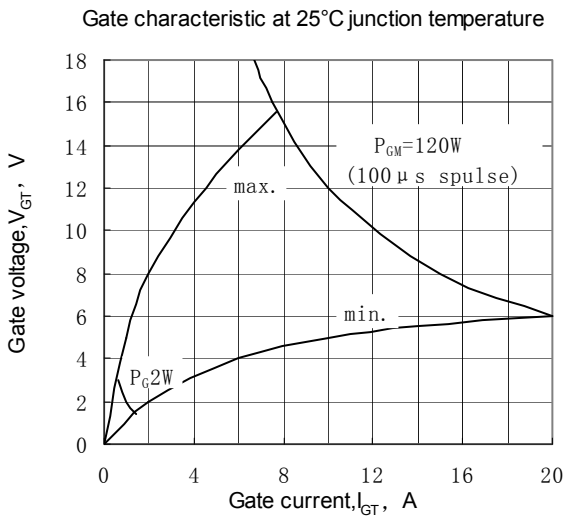

Fig.5

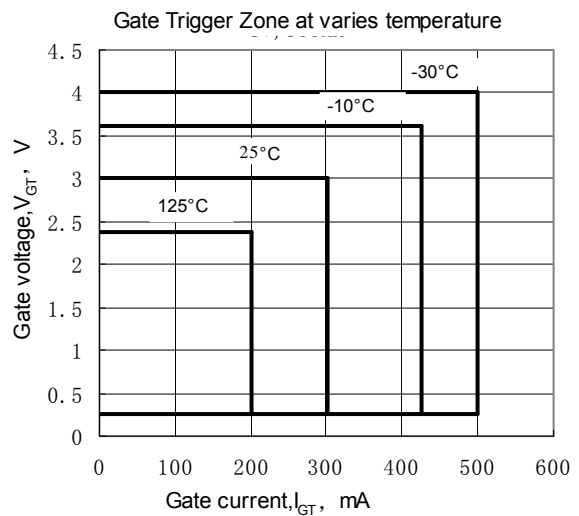
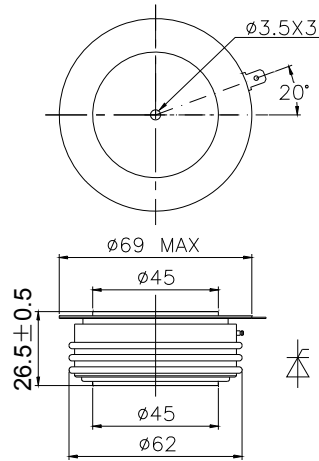

Fig.6



Outline: 图7-KT50cT



地 址 Address: 辽宁省锦州市滨海新区黔江街21号

邮 编 Zipcode: 121007

电 话 Telephone: 0416-2936666 18840127688

传 真 Fax: 0416-2936888

网 址 Web Sit: <http://www.power-semi.com>

电子邮箱 Email: 13904168481@126.com