



Features

- Interdigitated amplifying gates
- Fast turn-on and high di/dt
- Low switching losses

Typical Applications

- Inductive heating
- Electronic welders
- Self-commutated inverters

$I_{T(AV)}$ 600A
 V_{DRM}/V_{RRM} 1200~1800V
 t_q 16~35 μ s
 I_{TSM} 10 kA
 I^2t 500 10³A²S

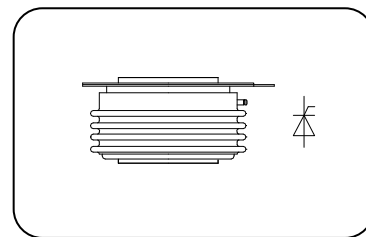

| SYMBOL | CHARACTERISTIC | TEST CONDITIONS | $T_j(^{\circ}C)$ | VALUE | | | UNIT |
|------------------------|--|--|------------------|-------|------|--------|----------------------------------|
| | | | | Min | Type | Max | |
| $I_{T(AV)}$ | Mean on-state current | 180° half sine wave 50Hz Double side cooled, $T_C=55^{\circ}C$ | 125 | | 600 | 1080 | A |
| V_{DRM} V_{RRM} | Repetitive peak off-state voltage Repetitive peak reverse voltage | $V_{DRM} \& V_{RRM}$, $t_p=10ms$ $V_{DSM} \& V_{RSM} = V_{DRM} \& V_{RRM} + 100V$ | 125 | 1200 | | 1800 | V |
| I_{DRM} I_{RRM} | Repetitive peak current | $V_D = V_{DRM}$ $V_R = V_{RRM}$ | 125 | | | 50 | mA |
| I_{TSM} | Surge on-state current | 10ms half sine wave | 125 | | | 10 | kA |
| I^2t | I^2T for fusing coordination | | | | | 500 | A ² s*10 ³ |
| V_{TO} | Threshold voltage | | 125 | | | 1.30 | V |
| r_T | On-state slop resistance | | 125 | | | 0.38 | m Ω |
| V_{TM} | Peak on-state voltage | $I_{TM}=1800A$, $F=18kN$ | 25 | | | 3.15 | V |
| dv/dt | Critical rate of rise of off-state voltage | $V_{DM}=0.67V_{DRM}$ | 125 | | | 1000 | V/ μ s |
| di/dt | Critical rate of rise of on-state current | $V_{DM}=67\%V_{DRM}$, $I_{TM}=(2-3)I_{TAV}$, $t=5s$ Gate pulse $t_r \leq 0.5\mu s$ $I_{GM}=1.5A$ $f=50Hz$ | 125 | | | 600 | A/ μ s |
| Q_{rr} | Recovery charge | $I_{TM}=1000A$, $t_p=1000\mu s$, $di/dt=-20A/\mu s$, $V_R=100V$ | 125 | | 550 | | μC |
| t_q | Circuit commutated turn-off time | $I_{TM}=1000A$, $t_p=1000\mu s$, $V_R=100V$ $dv/dt=30V/\mu s$, $di/dt=-20A/\mu s$ | 125 | 16 | | 35 | μs |
| I_{GT} | Gate trigger current | $V_A=12V$, $I_A=1A$ | 25 | 40 | | 200 | mA |
| V_{GT} | Gate trigger voltage | | | 0.9 | | 2.5 | V |
| I_H | Holding current | | | 20 | | 300 | mA |
| V_{GD} | Non-trigger gate voltage | $V_{DM}=67\%V_{DRM}$ | 125 | | | 0.3 | V |
| $R_{th(j-c)}$ | Thermal resistance Junction to case | At 180° sine double side cooled Clamping force 18kN | | | | 0.028 | $^{\circ}C/W$ |
| $R_{th(c-h)}$ | Thermal resistance case to heat sink | | | | | 0.0075 | |
| F_m | Mounting force | | | 15 | | 20 | kN |
| T_{stg} | Stored temperature | | | -40 | | 140 | $^{\circ}C$ |
| W_i | Weight | | | | 320 | | g |
| Outline | KT45cT | | | | | | |

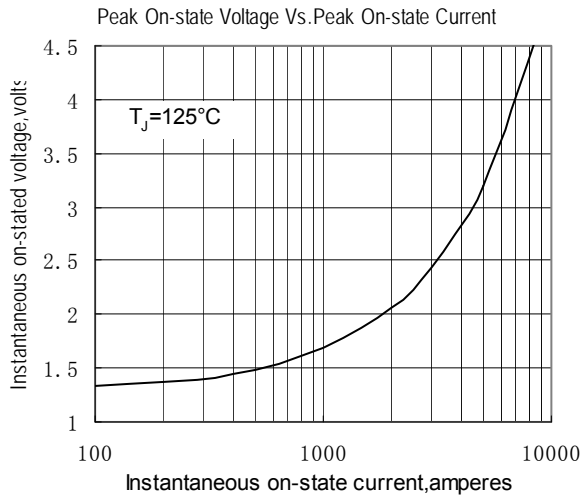

Fig.1

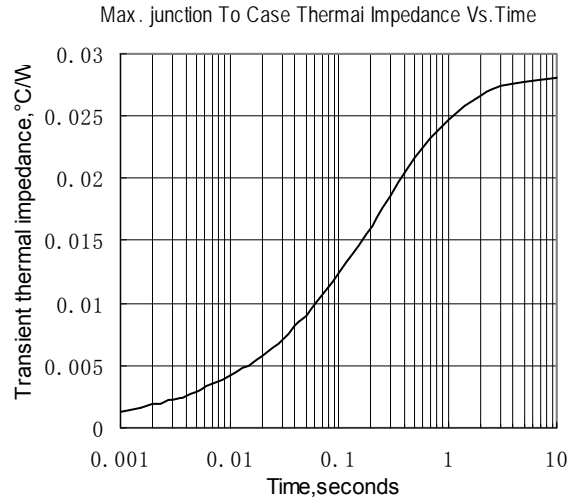

Fig.2

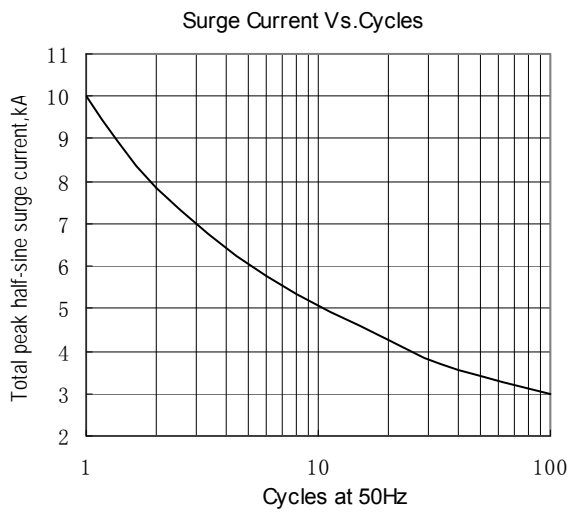

Fig.3

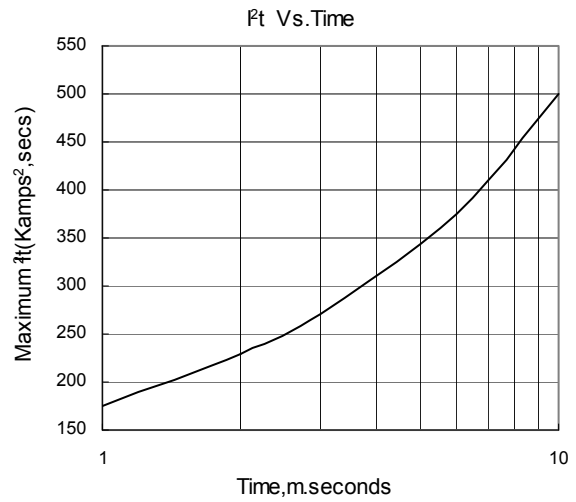

Fig.4

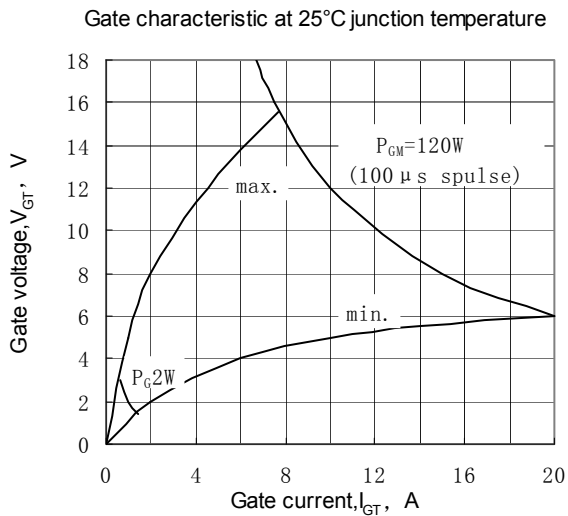

Fig.5

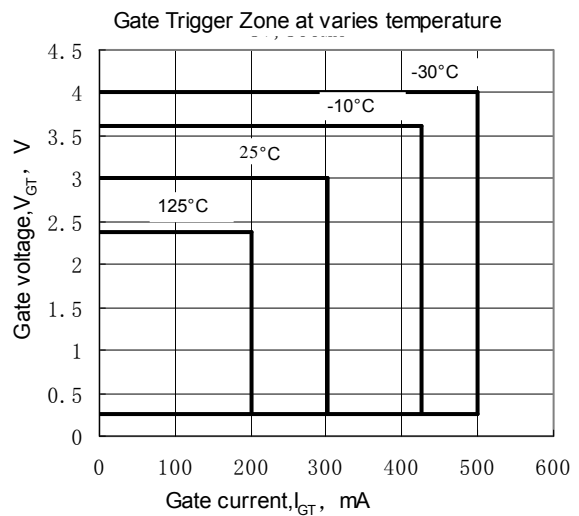
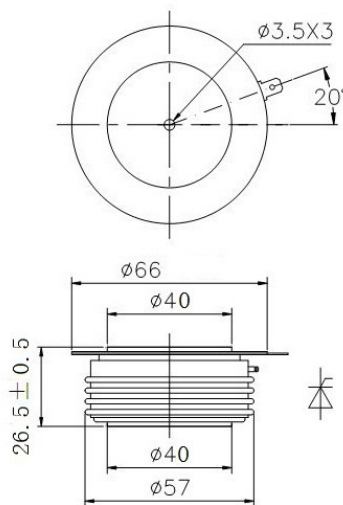

Fig.6



Outline:

图6-KT45cT



地 址 Address: 辽宁省锦州市滨海新区黔江街21号

邮 编 Zipcode: 121007

电 话 Telephone: 0416-2936666 18840127688

传 真 Fax: 0416-2936888

网 址 Web Sit: <http://www.power-semi.com>

电子邮箱 Email: 13904168481@126.com