

RDTST-9000/9100系列 (结构A)

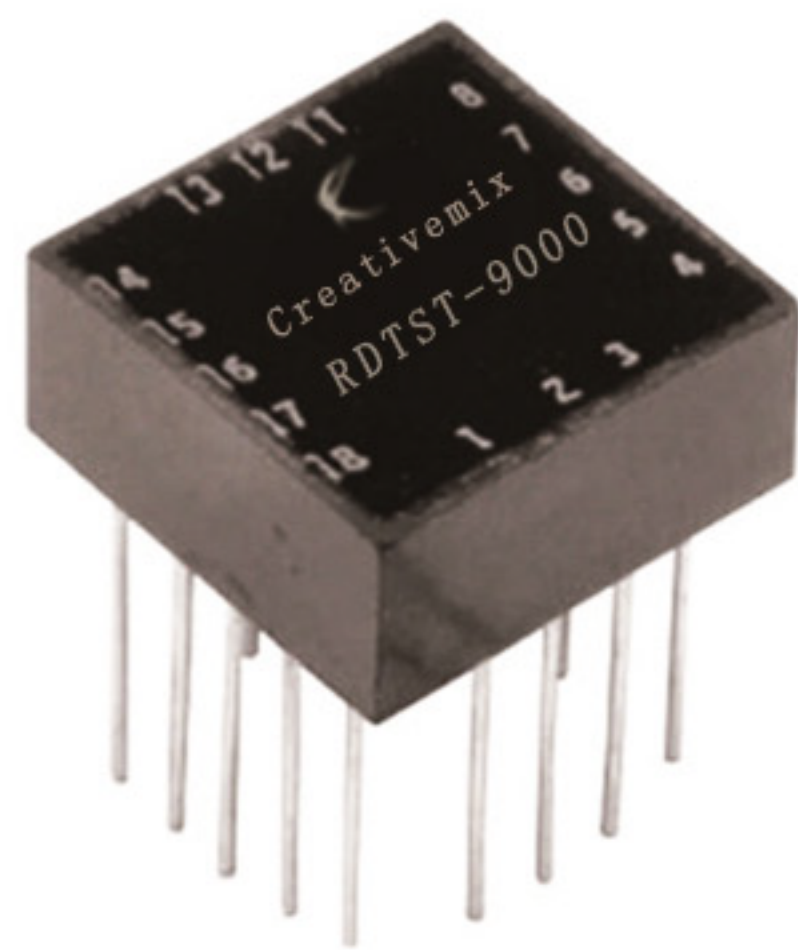

封装图

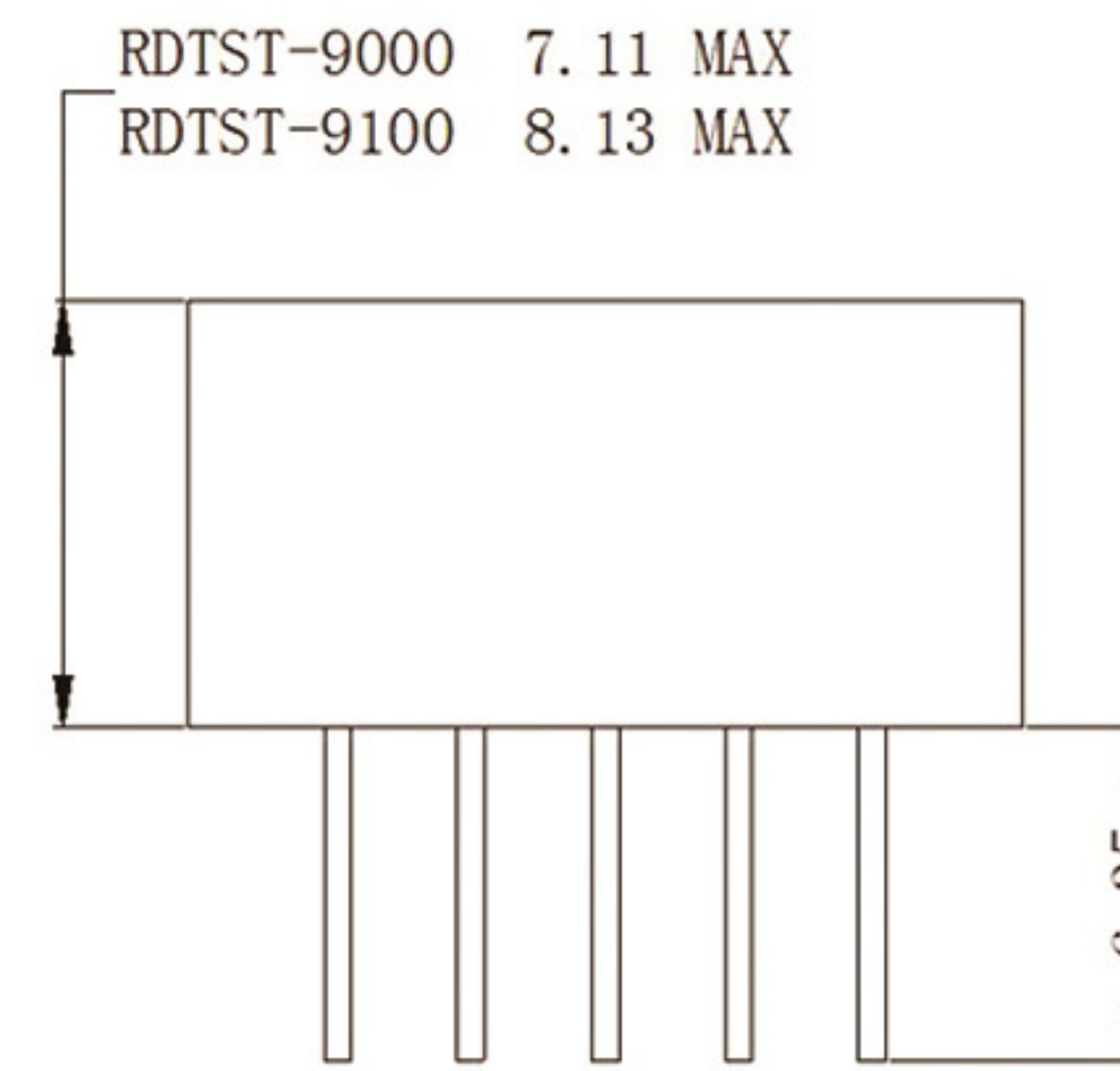
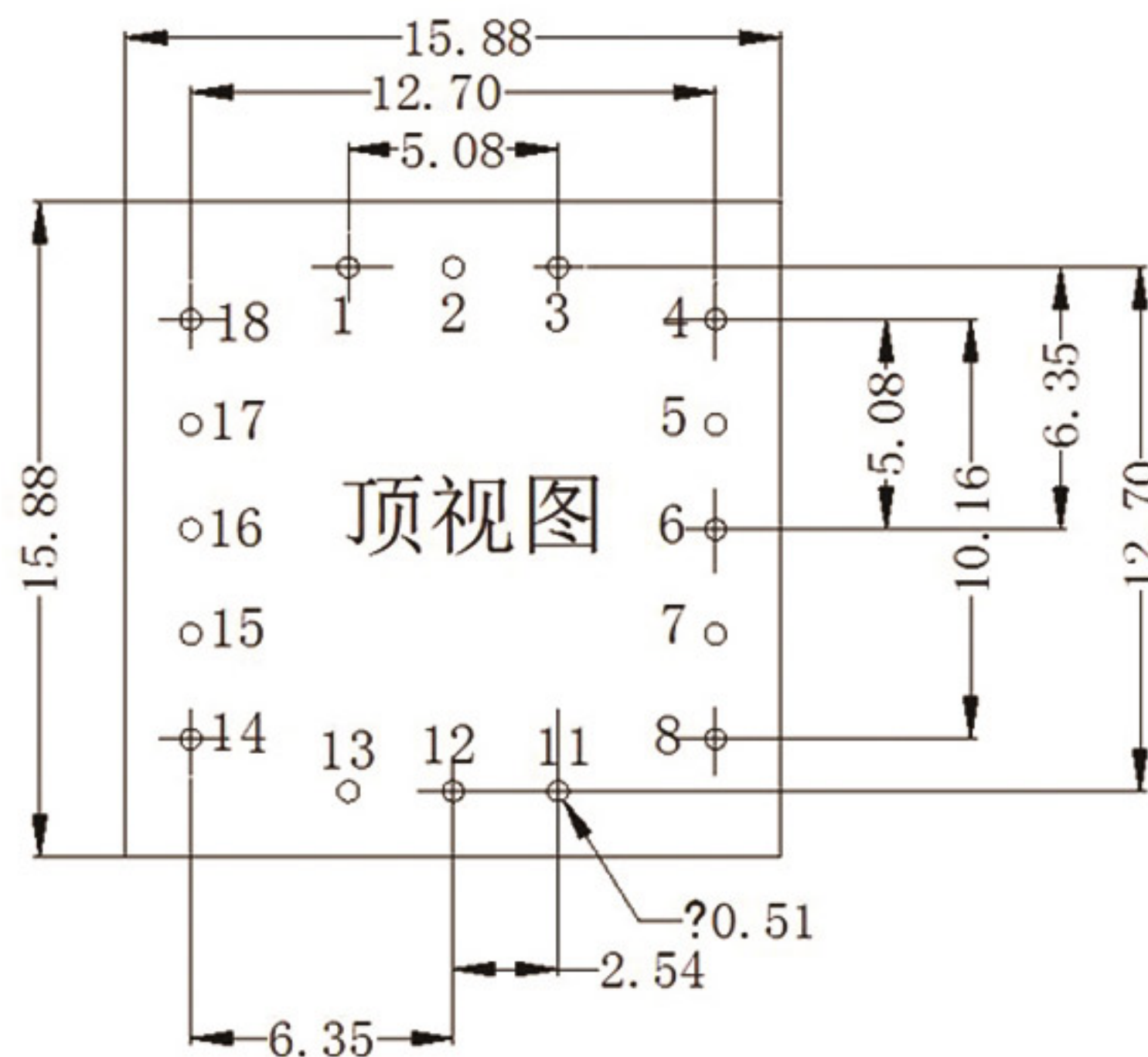

该系列是并排双路变压器

电原理图

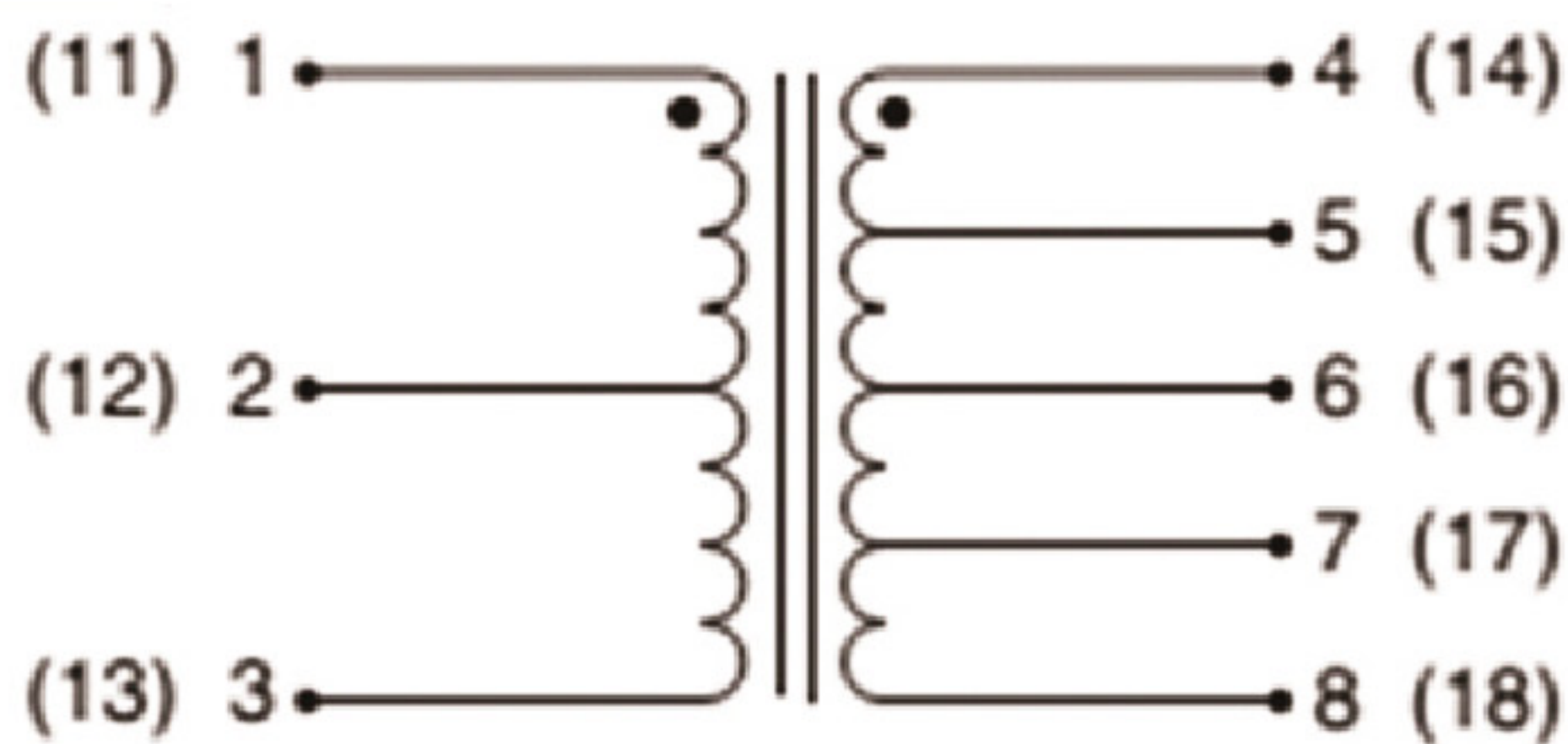

RDTST-9000,9001,9002,9003,9004,9006,9007
RDTST-9100,9101,9102,9103,9104,9106,9107

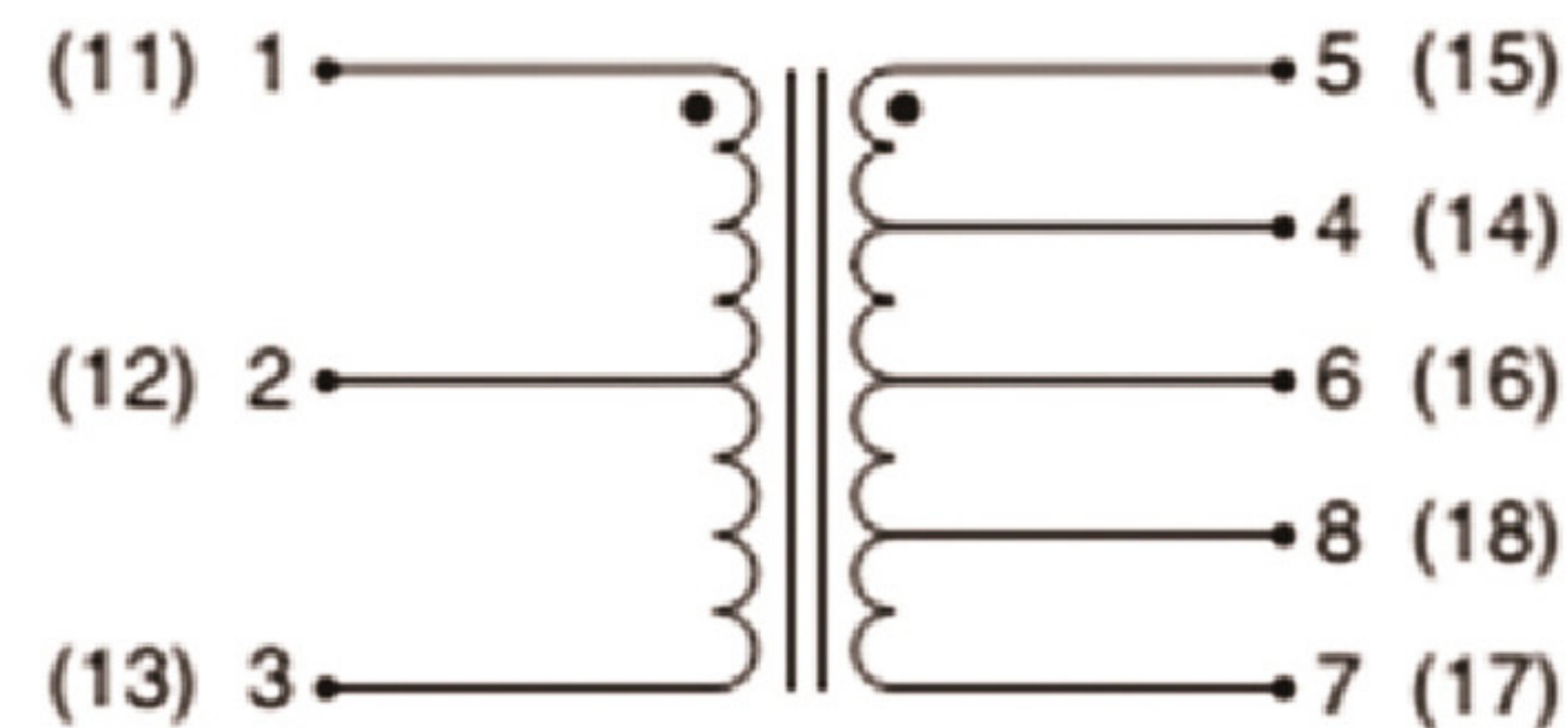

RDTST-9005
RDTST-9105

结构A电参数表

型号 P/N	匝比 TRUNS RATIO	初级 RRIMARY	次级 SECONDARY	直流电阻 DC RESISTANCE Ω(MAX)	输出上升时间 OUTPUT RISE TIME (MAX)	阻抗 IMPENDANCE Ω(MIN)	对应 DDC 型号
RDTST-9000/ RDTST-9100	2:5±3% 4:7±3%	1-3(11-13) 1-3(11-13)	4-8(14-18) 5-7(15-17)	1-3(11-13) 3.5 4-8(14-18) 3.0	150 ns	4-8,(14-18) 3000	TST-9000/ TST-9100
RDTST-9001/ RDTST-9101	1:0.83±3% 1:0.60±3%	1-3(11-13) 1-3(11-13)	4-8(14-18) 5-7(15-17)	1-3(11-13) 3.0 4-8(14-18) 3.0	150 ns	1-3,(11-13) 3000	TST-9001/ TST-9101
RDTST-9002/ RDTST-9102	1.4:1±3% 2:1±3%	1-3(11-13) 1-3(11-13)	4-8(14-18) 5-7(15-17)	1-3(11-13) 3.5 4-8(14-18) 3.0	150 ns	1-3,(11-13) 7200	TST-9002/ TST-9102
RDTST-9003/ RDTST-9103	1:1±3% 1:0.707±3%	1-3(11-13) 1-3(11-13)	4-8(14-18) 5-7(15-17)	1-3(11-13) 3.0 4-8(14-18) 3.0	150 ns	1-3,(11-13) 4000	TST-9003/ TST-9103
RDTST-9004/ RDTST-9104	1:2.5±3% 1:1.66±3%	1-3(11-13) 1-3(11-13)	4-8(14-18) 5-7(15-17)	1-3(11-13) 3.2 4-8(14-18) 3.0	150 ns	1-3,(11-13) 4000	TST-9004/ TST-9104
RDTST-9005/ RDTST-9105	2.3:1±3% 3.2:1±3%	1-3(11-13) 1-3(11-13)	4-8(14-18) 5-7(15-17)	1-3(11-13) 1.2 4-8(14-18) 3.0	150 ns	5-7,(15-17) 3000	TST-9005/ TST-9105
RDTST-9006/ RDTST-9106	2.12:1±3% 1.5:1±3%	1-3(11-13) 1-3(11-13)	4-8(14-18) 5-7(15-17)	1-3(11-13) 1.1 4-8(14-18) 3.0	200 ns	4-8,(14-18) 4000	TST-9006/ TST-9106
RDTST-9007/ RDTST-9107	1:2.5±3% 1:1.79±3%	1-3(11-13) 1-3(11-13)	4-8(14-18) 5-7(15-17)	1-3(11-13) 3.5 4-8(14-18) 4.0	250 ns	4-8,(14-18) 4000	TST-9007/ TST-9107

RDTST-9000/9100系列 (结构B)

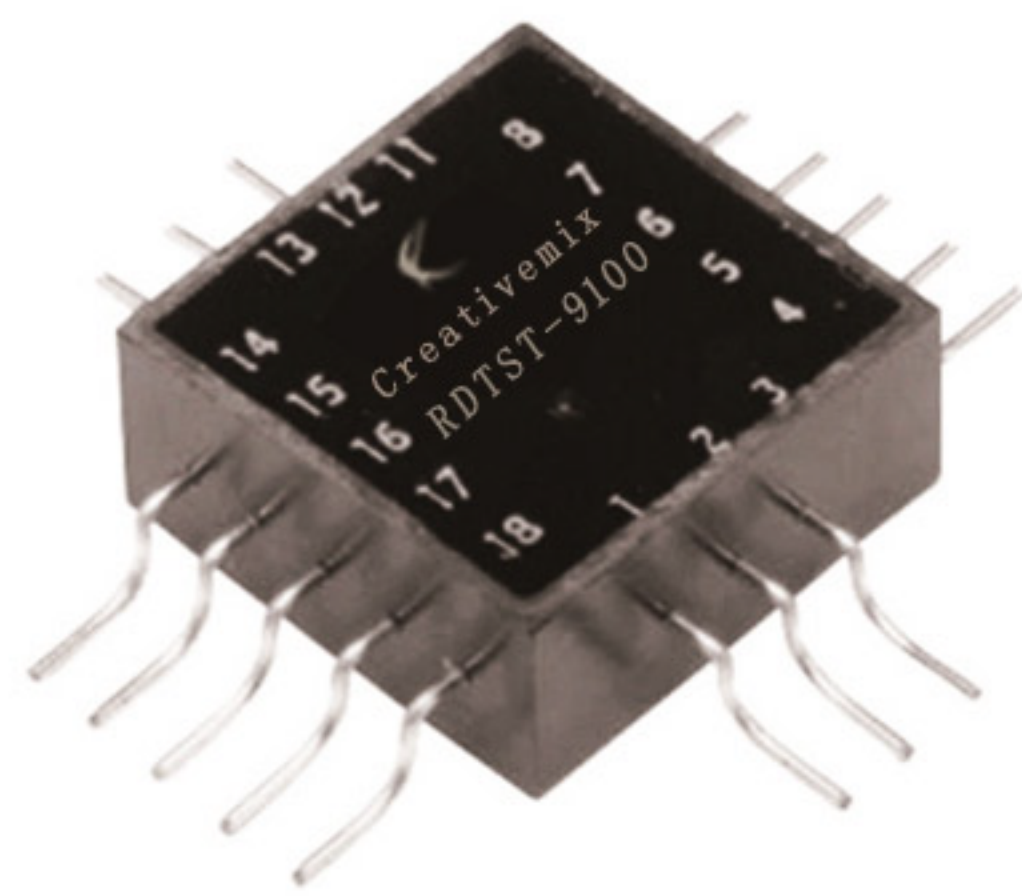

该系列是并排双路变压器

封装图

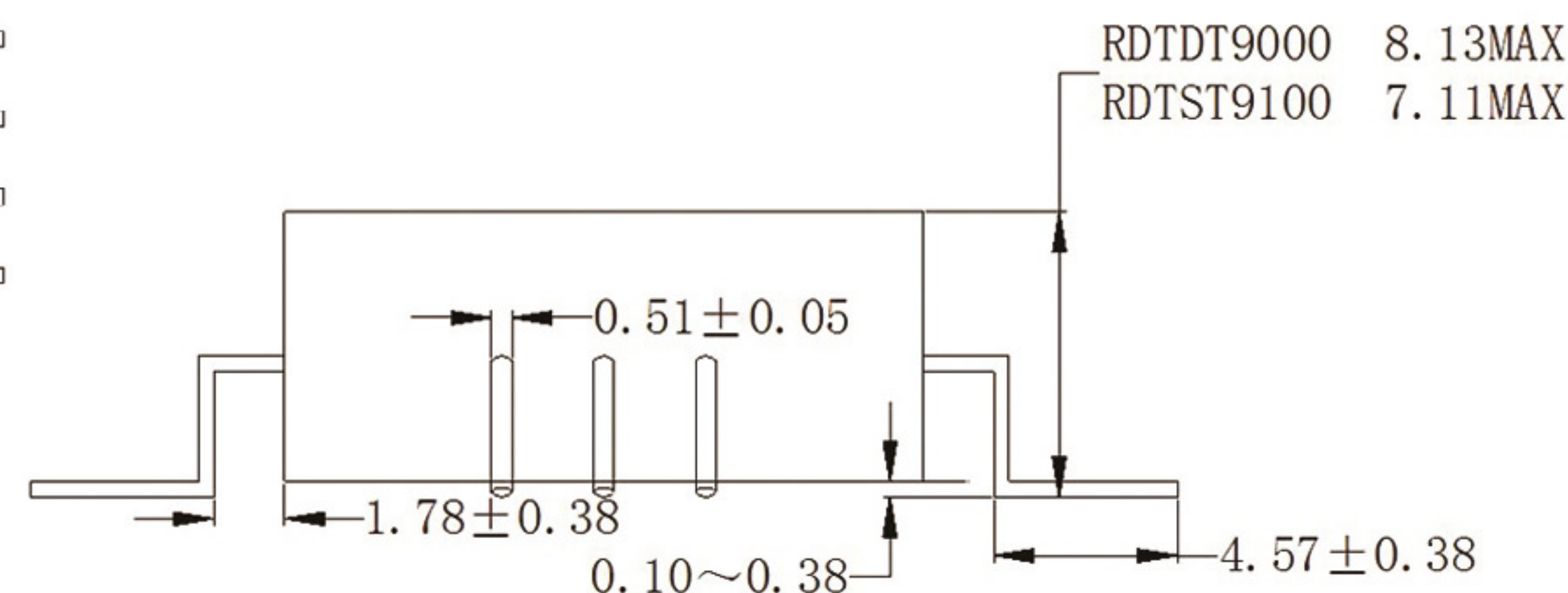
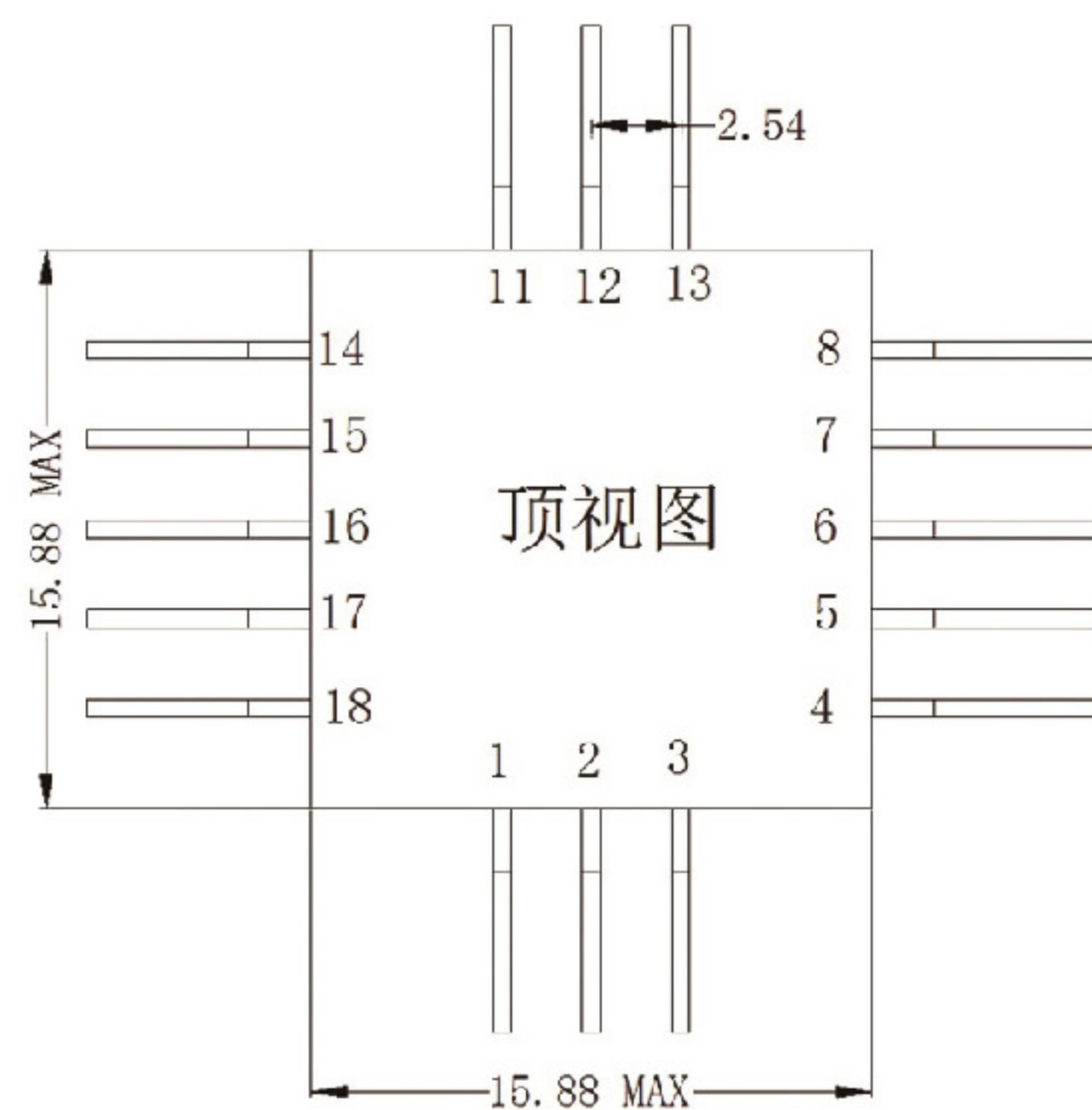

电原理图

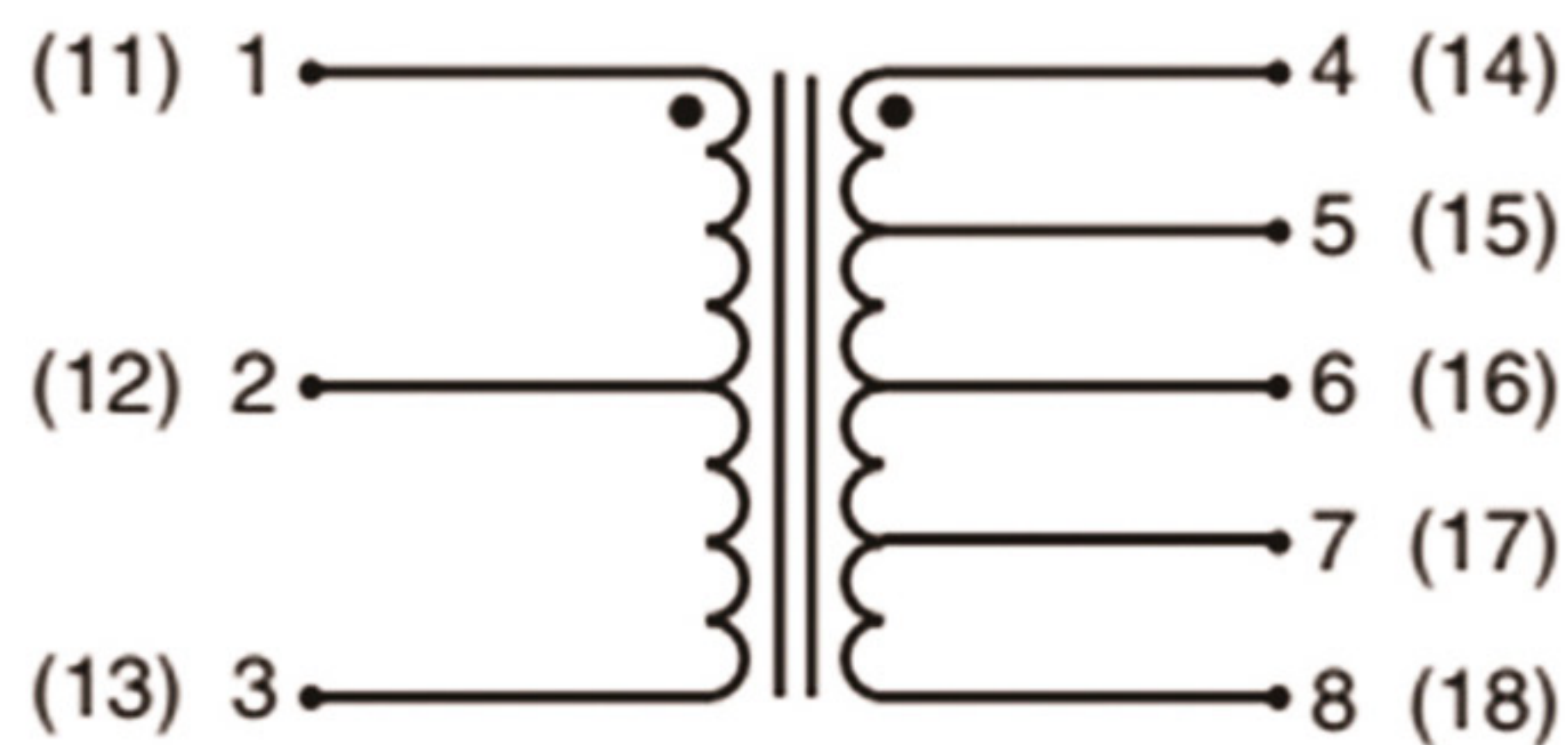

RDTST-9010,9011,9012,9013,9014,9016,9017
RDTST-9110,9111,9112,9113,9114,9116,9117

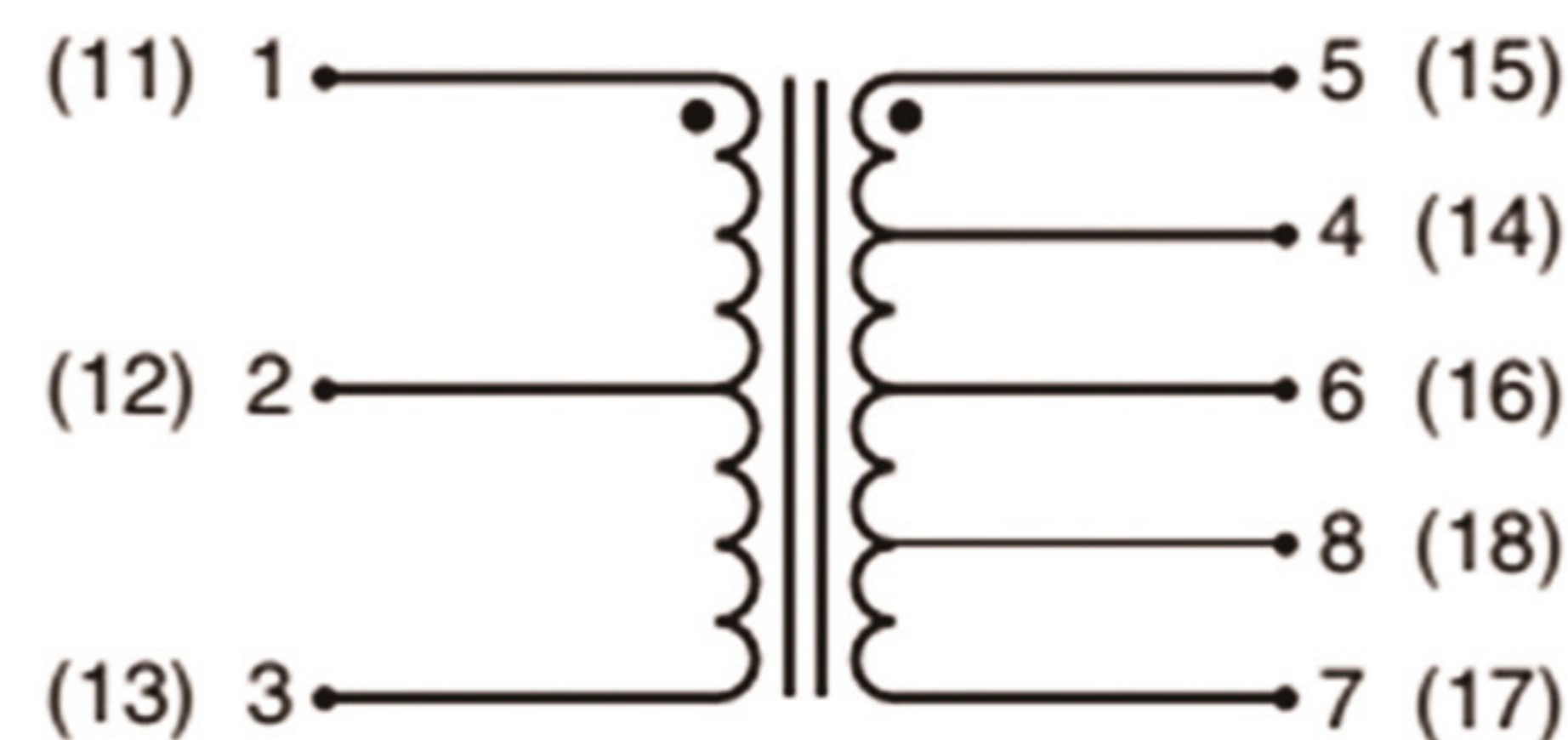

RDTST-9015
RDTST-9115

结构B电参数表

型号 P/N	匝比 TRUNS RATIO	初级 RRIMARY	次级 SECONDARY	直流电阻 DC RESISTANCE Ω(MAX)	输出上升时间 OUTPUT RISETIME (MAX)	阻抗 IMPENDANCE Ω(MIN)	对应 DDC 型号
RDTST-9010/ RDTST-9110	2:5±3% 4:7±3%	1-3(11-13) 1-3(11-13)	4-8(14-18) 5-7(15-17)	1-3(11-13) 3.5 4-8(14-18) 3.0	150 ns	4-8,(14-18) 3000	TST-9010/ TST-9110
RDTST-9011/ RDTST-9111	1:0.83±3% 1:0.60±3%	1-3(11-13) 1-3(11-13)	4-8(14-18) 5-7(15-17)	1-3(11-13) 3.0 4-8(14-18) 3.0	150 ns	1-3,(11-13) 3000	TST-9011/ TST-9111
RDTST-9012/ RDTST-9112	1.4:1±3% 2:1±3%	1-3(11-13) 1-3(11-13)	4-8(14-18) 5-7(15-17)	1-3(11-13) 3.5 4-8(14-18) 3.0	150 ns	1-3,(11-13) 7200	TST-9012/ TST-9112
RDTST-9013/ RDTST-9113	1:1±3% 1:0.707±3%	1-3(11-13) 1-3(11-13)	4-8(14-18) 5-7(15-17)	1-3(11-13) 3.0 4-8(14-18) 3.0	150 ns	1-3,(11-13) 4000	TST-9013/ TST-9113
RDTST-9014/ RDTST-9114	1:2.5±3% 1:1.66±3%	1-3(11-13) 1-3(11-13)	4-8(14-18) 5-7(15-17)	1-3(11-13) 3.2 4-8(14-18) 3.0	150 ns	1-3,(11-13) 4000	TST-9014/ TST-9114
RDTST-9015/ RDTST-9115	2.3:1±3% 3.2:1±3%	4-8(14-18) 5-7(15-17)	1-3(11-13) 1-3(11-13)	1-3(11-13) 1.2 4-8(14-18) 3.0	150 ns	5-7,(15-17) 3000	TST-9015/ TST-9115
RDTST-9016/ RDTST-9116	2.12:1±3% 1.5:1±3%	4-8(14-18) 5-7(15-17)	1-3(11-13) 1-3(11-13)	1-3(11-13) 1.1 4-8(14-18) 3.0	200 ns	4-8,(14-18) 4000	TST-9016/ TST-9116
RDTST-9017/ RDTST-9117	1:2.5±3% 1:1.79±3%	1-3(11-13) 1-3(11-13)	4-8(14-18) 5-7(15-17)	1-3(11-13) 3.5 4-8(14-18) 4.0	250 ns	4-8,(14-18) 4000	TST-9017/ TST-9117

RDTST-9000/9100系列 (结构C)

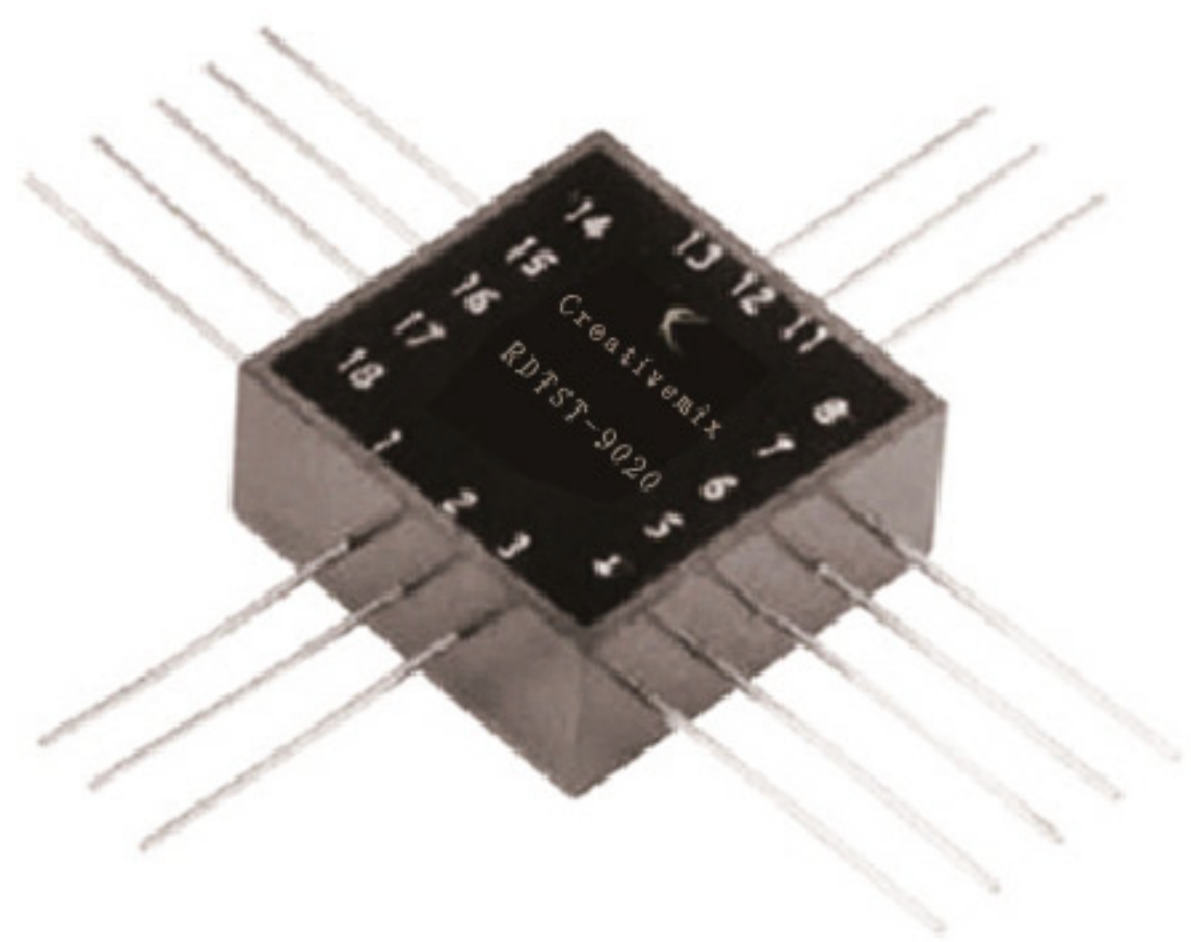

封装图

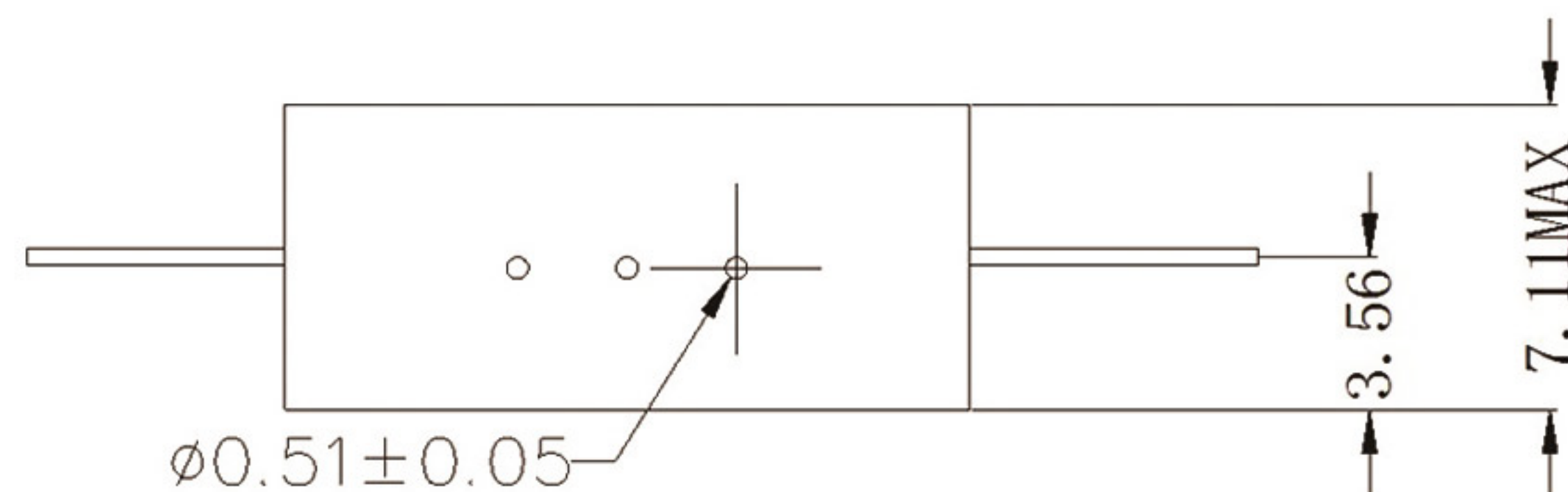
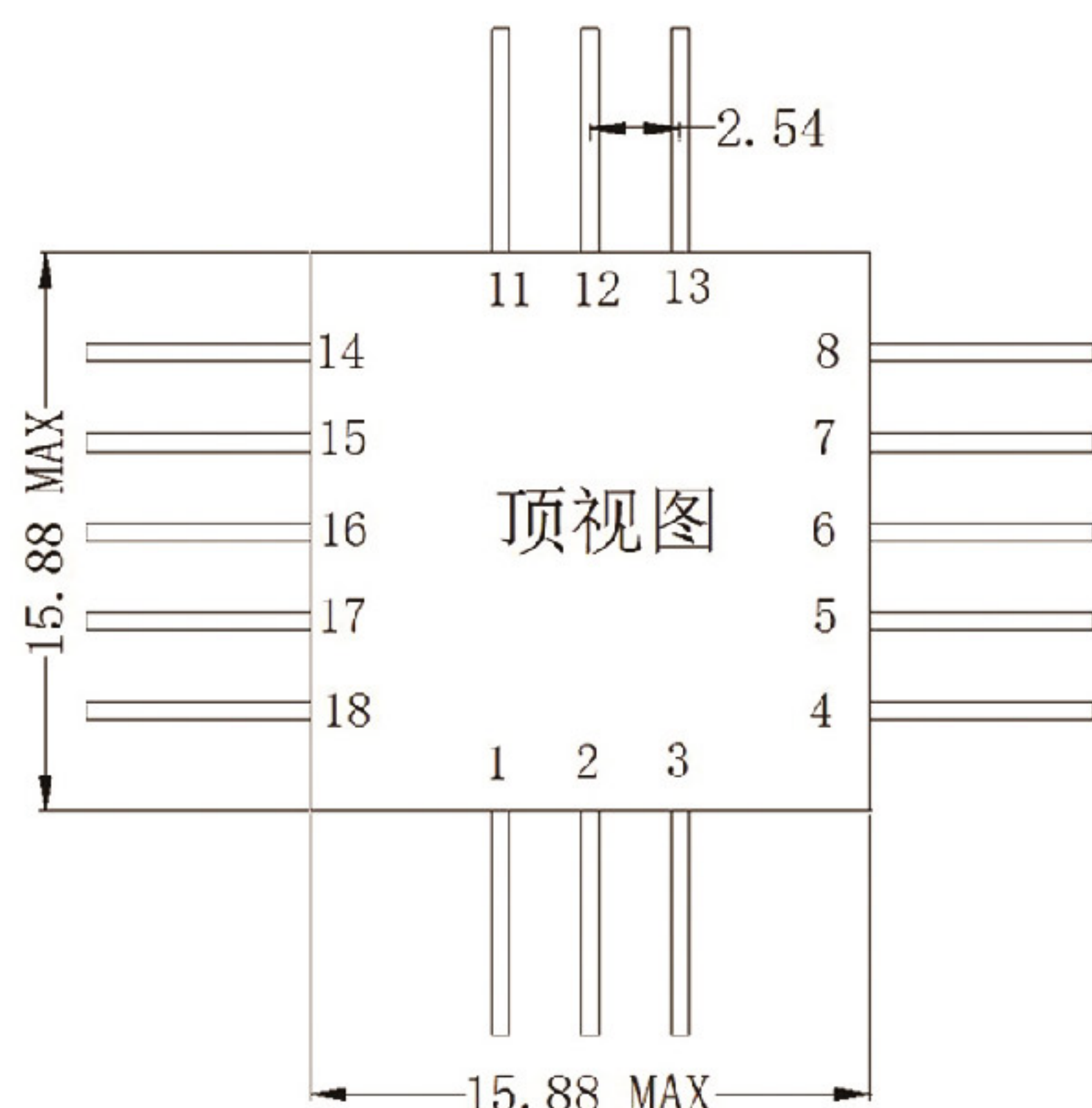

该系列是并排双路变压器

电原理图

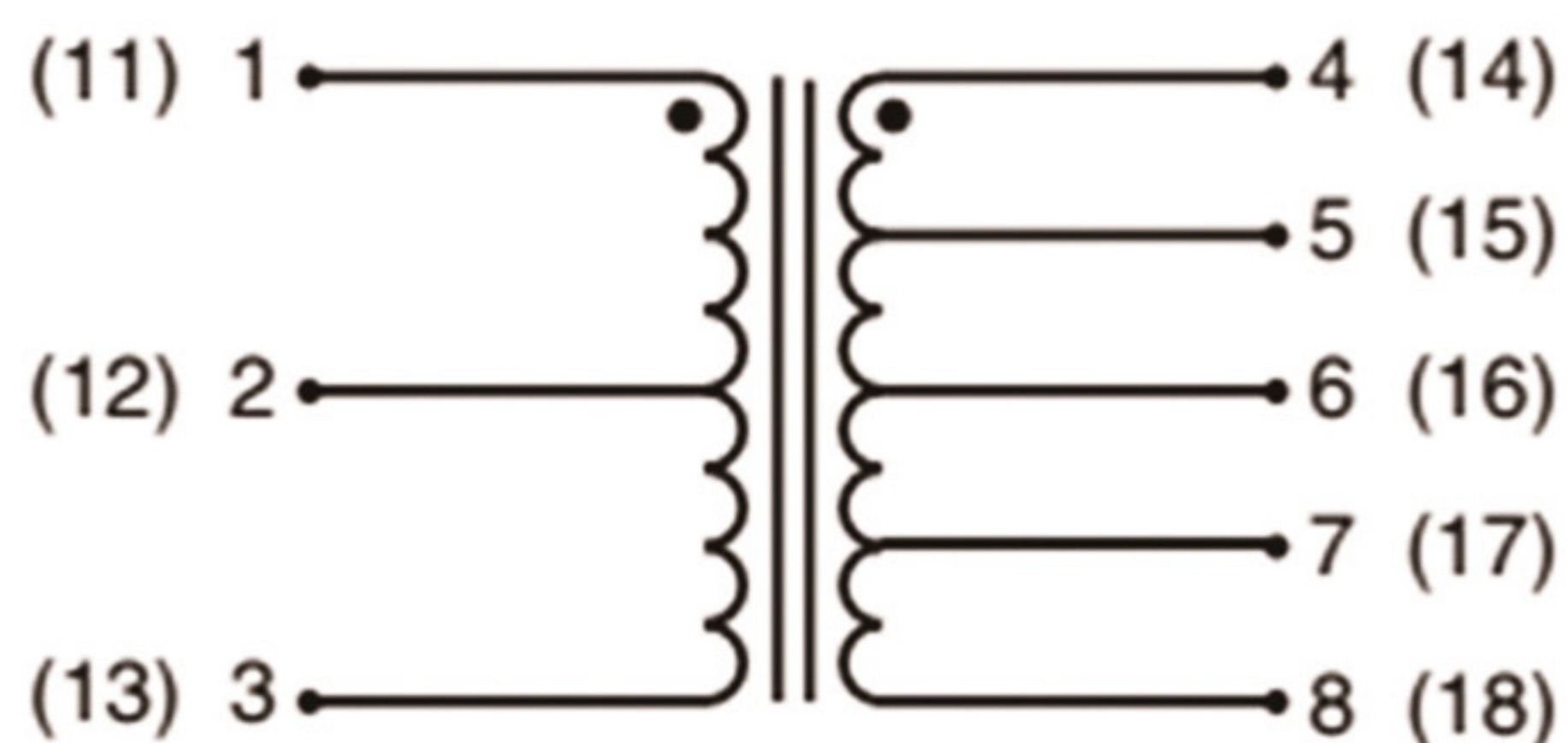

RDTST-9020,9021,9022,9023,9024,9026,9027
RDTST-9120,9121,9122,9123,9124,9126,9127

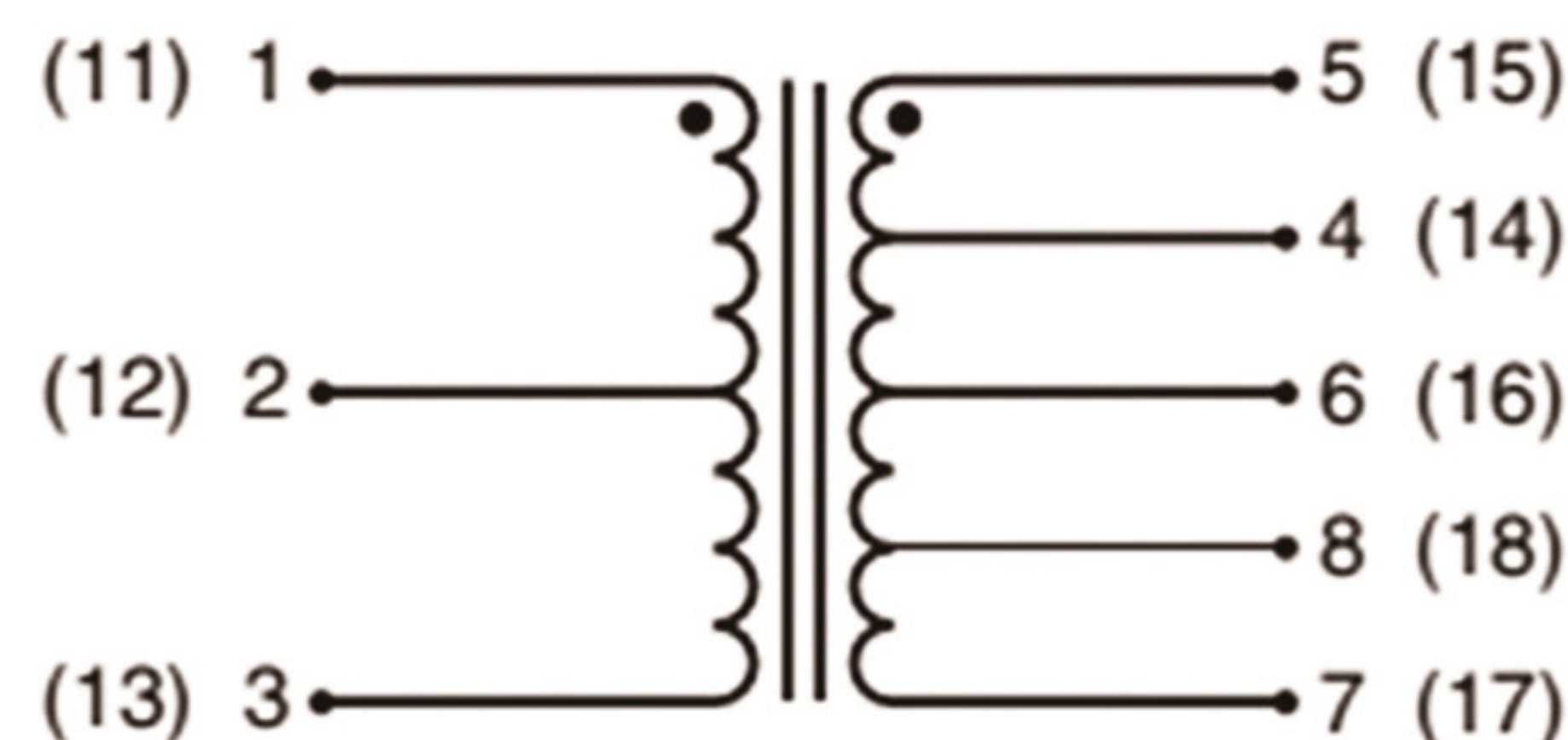

RDTST-9025
RDTST-9125

结构C电参数表

型号 P/N	匝比 TRUNS RATIO	初级 RRIMARY	次级 SECONDARY	直流电阻 DC RESISTANCE Ω(MAX)	输出上升时间 OUTPUT RISE TIME (MAX)	阻抗 IMPENDANCE Ω(MIN)	对应 DDC 型号
RDTST-9020/ RDTST-9120	2:5±3% 4:7±3%	1-3(12-13) 1-3(12-13)	4-8(14-18) 5-7(15-17)	1-3(12-13) 3.5 4-8(14-18) 3.0	150 ns	4-8,(14-18) 3000	TST-9020/ TST-9120
RDTST-9021/ RDTST-9121	1:0.83±3% 1:0.60±3%	1-3(12-13) 1-3(12-13)	4-8(14-18) 5-7(15-17)	1-3(12-13) 3.0 4-8(14-18) 3.0	150 ns	1-3,(13-13) 3000	TST-9021/ TST-9121
RDTST-9022/ RDTST-9122	1.4:1±3% 2:1±3%	1-3(12-13) 1-3(12-13)	4-8(14-18) 5-7(15-17)	1-3(12-13) 3.5 4-8(14-18) 3.0	150 ns	1-3,(12-13) 7200	TST-9022/ TST-9122
RDTST-9023/ RDTST-9123	1:1±3% 1:0.707±3%	1-3(12-13) 1-3(12-13)	4-8(14-18) 5-7(15-17)	1-3(12-13) 3.0 4-8(14-18) 3.0	150 ns	1-3,(12-13) 4000	TST-9023/ TST-9123
RDTST-9024/ RDTST-9124	1:2.5±3% 1:1.66±3%	1-3(12-13) 1-3(12-13)	4-8(14-18) 5-7(15-17)	1-3(12-13) 3.2 4-8(14-18) 3.0	150 ns	1-3,(12-13) 4000	TST-9024/ TST-9124
RDTST-9025/ RDTST-9125	2.3:1±3% 3.2:1±3%	4-8(14-18) 5-7(15-17)	1-3(12-13) 1-3(12-13)	1-3(12-13) 1.2 4-8(14-18) 3.0	150 ns	5-7,(15-17) 3000	TST-9025/ TST-9125
RDTST-9026/ RDTST-9126	2.12:1±3% 1.5:1±3%	4-8(14-18) 5-7(15-17)	1-3(12-13) 1-3(12-13)	1-3(12-13) 1.1 4-8(14-18) 3.0	200 ns	4-8,(14-18) 4000	TST-9026/ TST-9126
RDTST-9027/ RDTST-9127	1:2.5±3% 1:1.79±3%	1-3(12-13) 1-3(12-13)	4-8(14-18) 5-7(15-17)	1-3(12-13) 3.5 4-8(14-18) 4.0	250 ns	4-8,(14-18) 4000	TST-9027/ TST-9127