

1. Description

The ES1450 is a dual channel switch Hall sensor with two Hall sensing elements. It outputs two digital signals for speed processing.

The ES1450 internally includes two Hall sensing elements located 1.40mm apart, an on-chip Hall voltage generator, voltage regulator for operation with supply voltage 2.7 to 24V, temperature compensation circuitry, small-signal amplifier, Hall sensor with dynamic offset cancellation system, Schmitt trigger and open-drain output. Signal processing of speed and signals is easy.

The ES1450 provides a variety of packages to customers: flat TO-94 for through-hole mount and SOT-23-6L for surface mount. All packages are RoHS compliant.

2. Product Image



3. Features

- ◆ 1.4mm Hall Elements Spacing
- ◆ Dual channel and open-drain output
- ◆ High Magnetic Sensitivity: +/-18GS
- ◆ Supply Voltage Range: 2.7 ~ 24V
- ◆ Specified Operation Temperature Range: -40°C ~ 150°C
- ◆ Antistatic ability 6KV HBM

4. Applications

- ◆ Magnetic encoder
- ◆ Speed detection
- ◆ Direction detection
- ◆ UAV
- ◆ Robots
- ◆ Fitness equipment

5. Functional Block Diagram

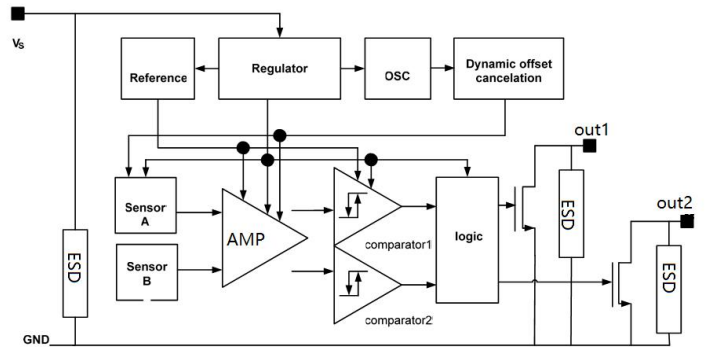

6. Pin Definitions and Descriptions

TO	SOT	名称	功能
1	4	VDD	Supply voltage
2	1	OUT1	Output 1
3	3	OUT2	Output 2
4	5/6	GND	Ground

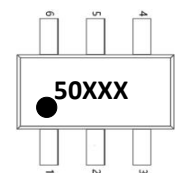
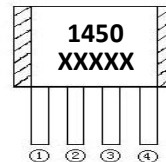

7. Absolute Maximum Ratings

Parameter	Value	Units
Supply Voltage (Vcc)	-15 ~ +30	V
Junction Temperature	165	°C
Operating Temperature Range	-40 ~ 150	°C
Storage Temperature Range	-55 ~ 150	°C

Note: Absolute maximum ratings are limiting values to be applied individually, and beyond which the serviceability of the circuit may be impaired. Functional operability is not necessarily implied. Exposure to absolute maximum rating conditions for an extended period of time may affect device reliability.

8. Electrical and Magnetic Characteristic

$T_A = 25^\circ\text{C}$, $V_{DD} = 12\text{V}$

Parameter	Symbo	Test Condition	Min	Typ	Max	Units
Supply Voltage	V_{DD}	$T_J < T_J(\text{max})$	2.7	5	24	V
Supply Current	I_{DD}	$B < B_{RP}$		5.5	7.0	mA
Output Saturation	V_{SON}	$I_{OUT} = 20\text{mA}$, $B > B_{OP}$	-	-	0.4	V
Output Leakage Current	I_{OFF}	$B < B_{RP}$, $V_{OUT} = 24\text{V}$	-	0.1	1.0	μA
Output Rise Time	T_R	$R_L = 10\text{kohm}$, $C_L = 20\text{pF}$	-	-	1.0	μs
Output Fall Time	T_F	$R_L = 10\text{kohm}$, $C_L = 20\text{pF}$	-	-	1.0	μs
Delay Time 1	T_{D1}		-	1.4	-	μs
Delay Time 2	T_{D2}		-	1.0	-	μs
Magnetic Release Point	B_{OP}		10	18	30	Gs
Magnetic Release Point	B_{RP}		-30	-18	-10	Gs
Hysteresis Window	B_{HYST}	$ B_{OP} - B_{RP} $		36		Gs
Distance of Hall	D_{IS}		1.39	1.40	1.41	mm

9. Typical Application circuit

TO-94 Package

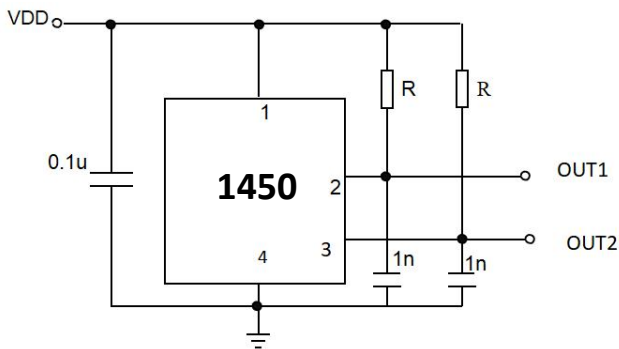

10. Typical Output maveform

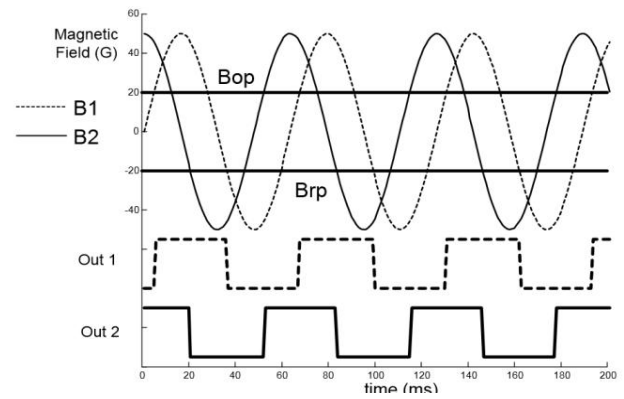

11. Characteristic Performance

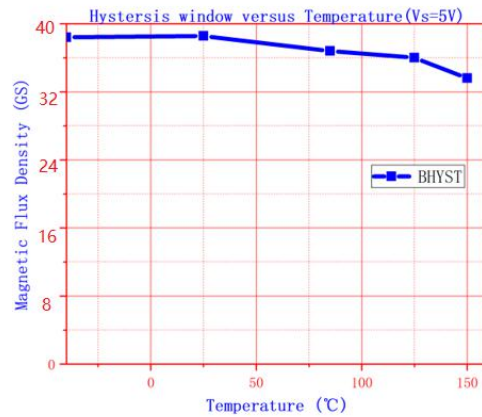
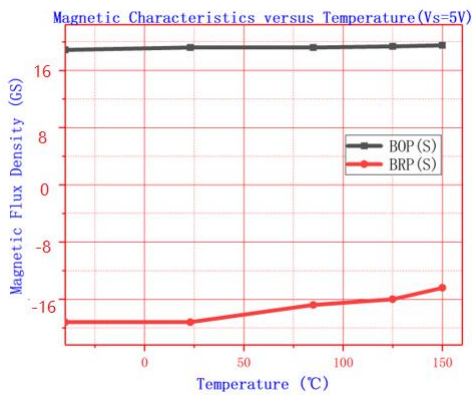
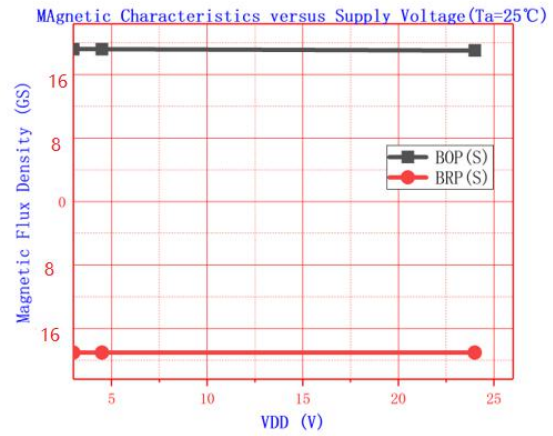
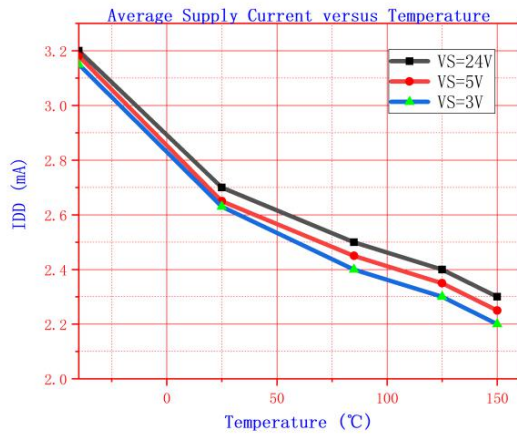

12. Package Information

12.1 VK (TO - 94)

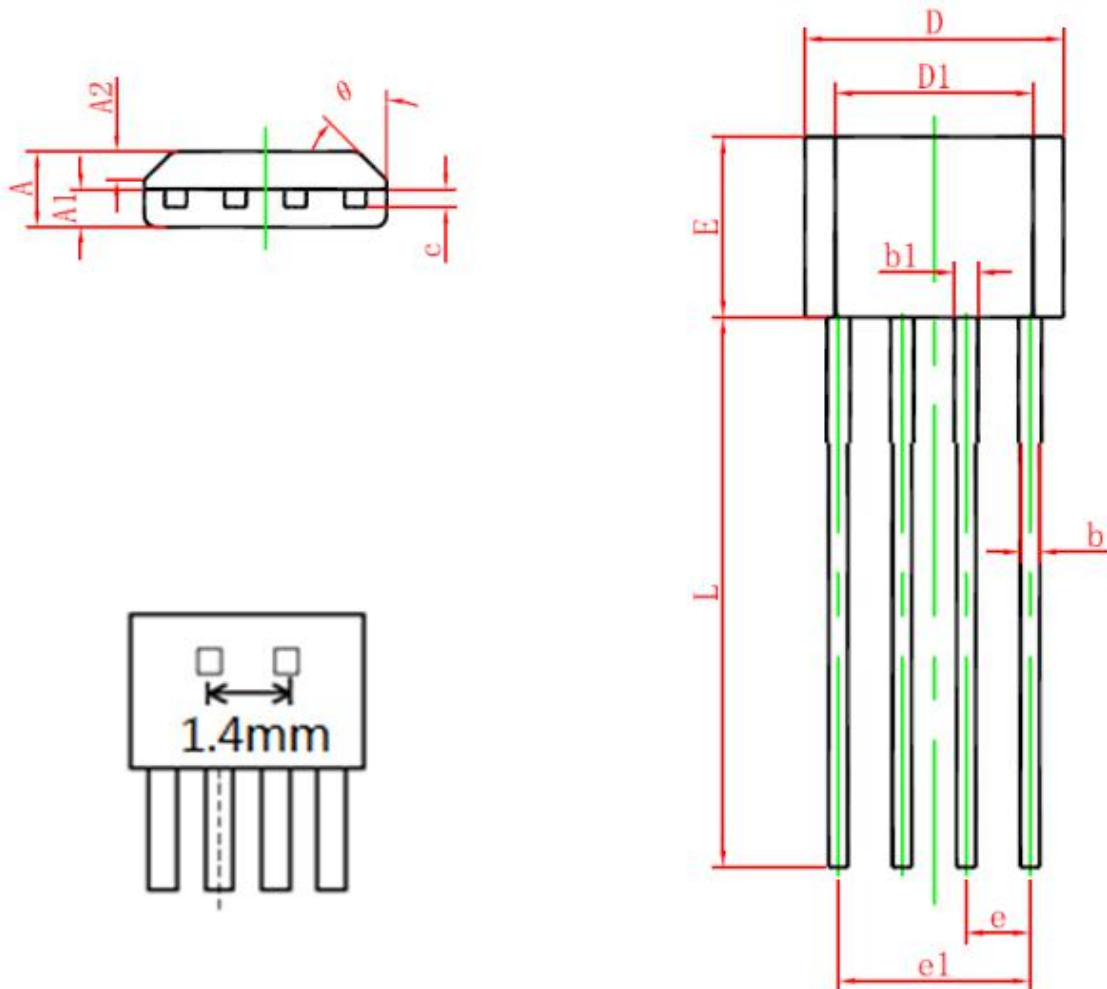

Symbol	Dimensions In Millimeters		Dimensions In Inches	
	Min.	Max.	Min.	Max.
A	1.400	1.800	0.055	0.071
A1	0.700	0.900	0.028	0.035
A2	0.500	0.700	0.020	0.028
b	0.360	0.500	0.014	0.020
b1	0.380	0.550	0.015	0.022
c	0.360	0.510	0.014	0.020
D	4.980	5.280	0.196	0.208
D1	3.780	4.080	0.149	0.161
E	3.450	3.750	0.136	0.148
e	1.270 TYP.		0.050 TYP.	
e1	3.710	3.910	0.146	0.154
L	14.900	15.300	0.587	0.602
θ	45° TYP.		45° TYP.	

12.2 S6(SOT23-6L)

Pin: pin1 OUT1 pin2 null
 Pin3 OUT2 pin4 V_{DD}
 Pin5 GND pin6 GND

Marking:

50 – product code (ES1450);
 xxx – batch number;

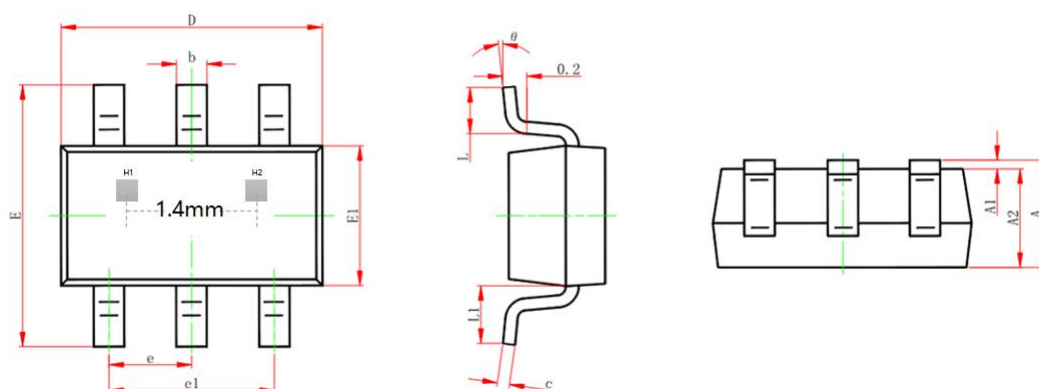
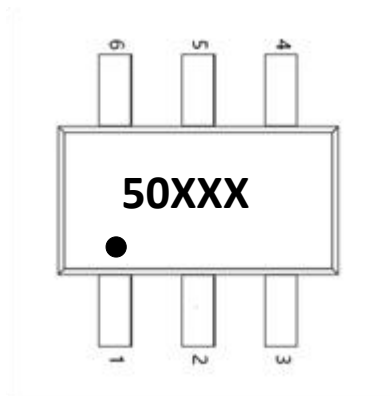

Symbol	Dimensions in MM		Dimensions in Inches	
	Min	Max	Min	Max
A	1.05	1.25	0.041	0.049
A1	0.000	0.100	0.000	0.004
A2	1.050	1.150	0.041	0.045
b	0.300	0.500	0.012	0.020
c	0.100	0.200	0.004	0.008
D	2.820	3.020	0.111	0.119
E1	1.500	1.700	0.059	0.067
E	2.650	2.950	0.104	0.116
e	0.950 TYP		0.037 TYP	
e 1	1.800	2.000	0.071	0.079
L	0.300	0.600	0.012	0.024
L1	0.600 TYP		0.024 TYP	
θ	0°C	8°C	0°C	8°C

13. Ordering Information

Part No.	TEMP	Package Code
ES1450	E(-40-85°C)	S6(SOT23-6L)
		VK(TO-94)
	L(-40-150°C)	S6(SOT23-6L)
		VK(TO-94)