

COMMERCIAL ULTRASONIC GAS METER



MAIN FEATURES

- Wide range ratio:the range ratio can be up to 250:1.
- TC/TPC:temperature compensation or pressure and temperature compensation optional.
- Size:compact design,easy to install.
- Dual lithium battery:replaceable battery with transmission of low battery and battery-removal alarms;second internal battery for back-up when the replaceable battery is removed.
- Safety:high flow/temperature/pressure alarm,air detection alarm,cover opened alarm.
- History record:hour record,day record,month record.
- Communication modules:NB-IoT/LTE-M.
- Optical port:IEC62056-21.

DIMENSIONS

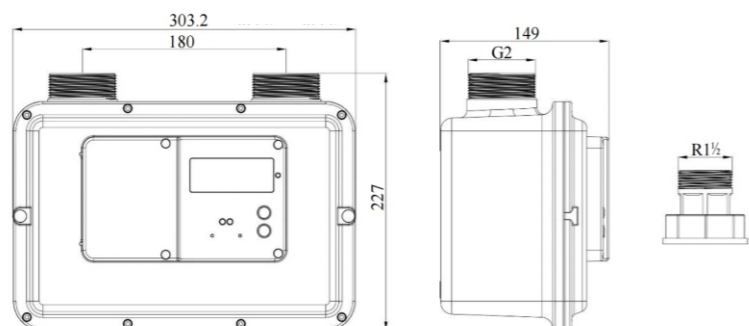

SPECIFICATIONS

Tech Specs	G6	G10	G10W	G16	G25	G25W
Qmax(m ³ /h)	10	16	16	25	40	40
Qmin(m ³ /h)	0.06	0.1	0.06	0.16	0.25	0.16
Qt(m ³ /h)	1.0	1.6	1.0	2.5	4	2.5
Max Operating Pressure	30kPa					
Accuracy	1.5					
Operating Temperature	-25°C~55°C					
Ingress Protection	IP65					
Explosion Protection	Ex ib IIB T3 GB					
Gas Type	Nature gas H,L,E					
Communication Module	NB-IoT/LTE-M					
Optical Port	IEC 62056-21					
Battery Life	10years					
Hub Center-to-Center	180mm					
Hub Size	G2"					