

CAD GENERATED DRAWING. DON'T CHANGE BY HAND.

REV.	ECN. NO.	APPD.

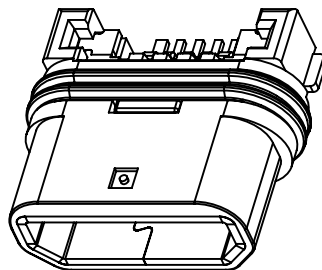
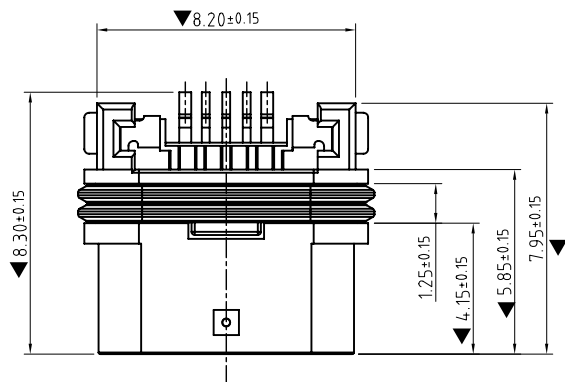

Notes:

1. Dimension shall be interpreted per ASME Y14.5M1994.
2. Dimension marked ∇ & \blacktriangledown should be checked by Q.C. and process, engineers and ∇ should also check the CPK data.

Specification:

1. Current Rating: 1.0 AMP
2. Voltage Rating: 30V AC,DC
3. Dielectric Strength: 500V AC RMS for 1 minute.
4. Contact Resistance: 30 m Ω Max.
5. Insulator Resistance: 500M Ω Min. AT 250V DC.
6. Mating/Unmating cycles: 2000cycles
7. Temperature: -20°C to +60°C

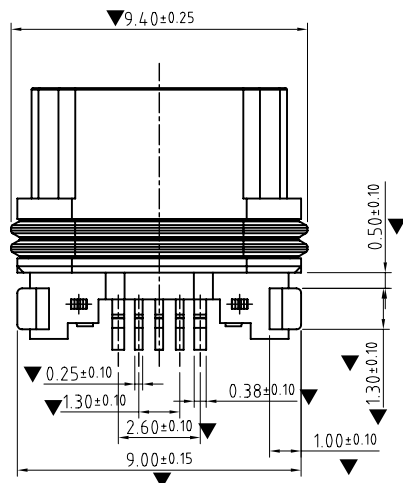
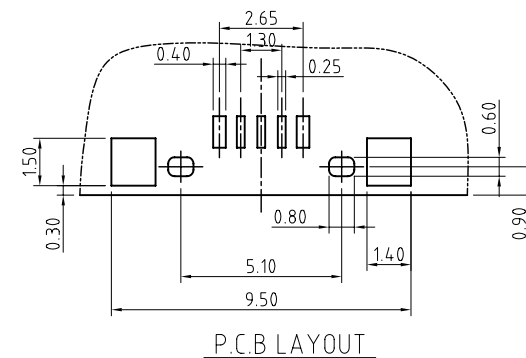
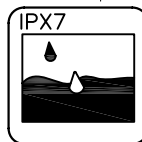
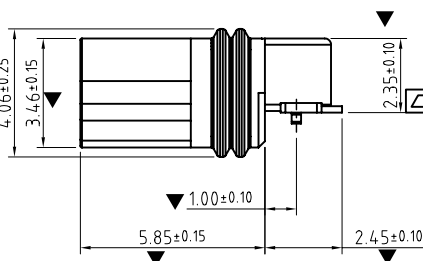
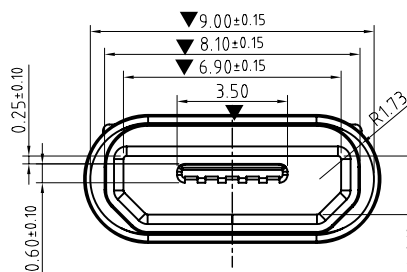

3	Shell	1	C2680R-H Au/Ni Plating T=0.30mm	
3	Contact	5	Phosphor bronze C5210R-EH Au/Ni Plating T=0.20mm	
2	Housing-2	1	PA9T&LCP (G.F30%)	
1	Housing-1	1	PA9T&LCP (G.F30%)	
ITEM	PART NAME	Q'TY	FINISH	NOTE

X. ± 0.50	X° $\pm 2^\circ$	UNITS mm	协展电子科技有限公司 Xie Zhan Electronic Technology Co., Ltd	TITLE: Micro USB 5Pin SMT (B) Type (沉板平口防水型 No spring)
.X ± 0.30	X° $\pm 1^\circ$			
.XX ± 0.10	.XX° $\pm 0.5^\circ$	MAT'L	PART NO. (INTENDED USE)	DWG NO.: 规格书(Z4&Z5)USB
XXX ± 0.05		FINISH	APPD:	DR: Steven.Xie 2016/03/19
		Q'TY	CHKD:	
THESE DRAWINGS AND SPECIFICATIONS ARE THE PROPERTY OF XIE ZHAN ELECTRONIC TECHNOLOGY CO.,LTD.AND SHALL NOT BE REPRODUCED, COPIED OR USED IN ANY MANNER WITHOUT THE PRIOR WRITTEN CONSENT OF XIE ZHAN ELECTRONIC TECHNOLOGY CO., LTD			SCALE SHEET REV. 1/1 1/1 A1	

由 Autodesk 教育版产品制作

由 Autodesk 教育版产品制作