

REV.	ECN NO.	DESCRIPTION	DRAW	APPD.	DATE
A	---	新版本发行			2019.07.09

NOTES:

SPECIFICATION:

1. CURRENT RATING: 3.0A MAX
2. VOLTAGE: 100 VAC
3. TEMPERATURE RANGE: -30 °C ~ 85 °C
4. CONTACT RESISTANCE: 40 MILLIONHM MAX
5. INSULATION RESISTANCE: 100 MEGOHMS MIN.
6. LNSERTION FORCE : 5N~20N
7. UNMATING FORCE: 8N~20N
8. DURABILITY: 2,000 CYCLES

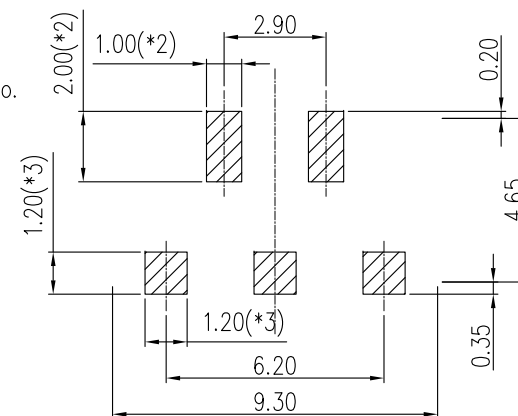
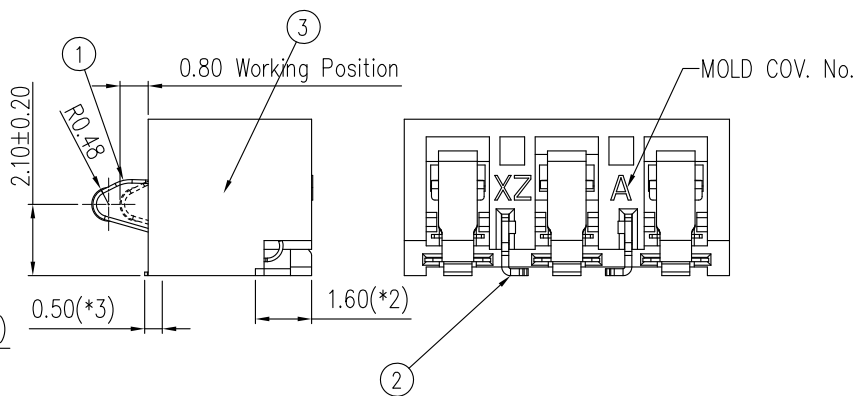
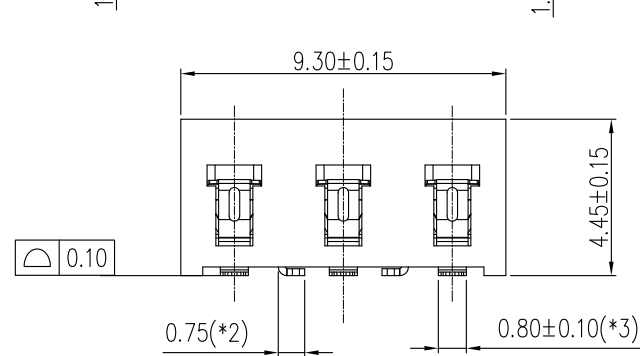
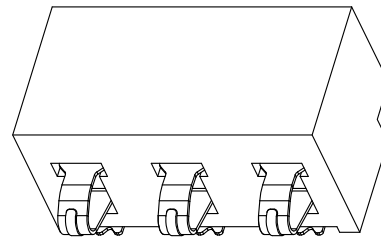
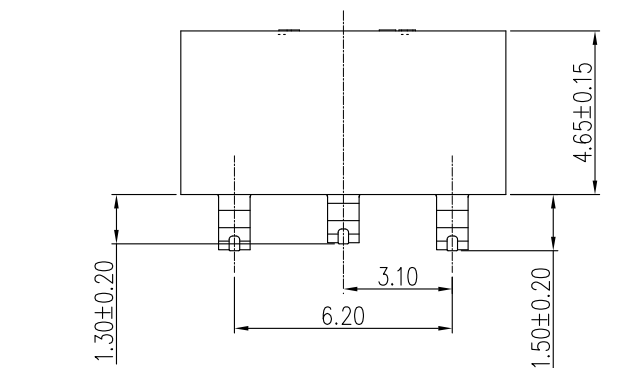

RECOMMENDED P.C.B. LAYOUT  
TOLERANCE UNSPECIFIED ±0.05mm

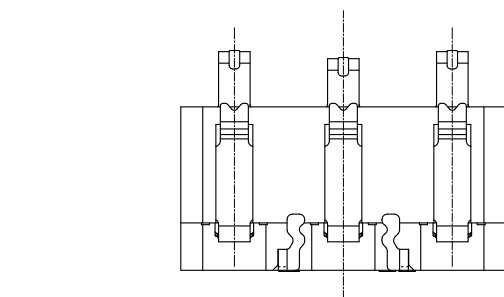

3	HOUSING	HIGH TEMPERATURE PLASTIC	BLACK	1PCS
2	NAIL	STAINLESS STEEL	Tin/Ni Plated	2PCS
1	CONTACT	COPPER ALLOY	Au/Ni Plated	3PCS
NO.	DESCRIPTION	MATERIAL	REMARKS	QTY

TOLERANCE		NAME(INTENDED USE) CUSTOMER DRAWING		东莞市协展电子科技有限公司	
X.X ±0.30	X.* ± 2°	PART NO.		TITLE: 3 PIN BATTERY(3.10 PITCH)	
.XX ±0.20	.X* ± 1°	APPD:		DRAWG NO. (N3310-2017)	
.XXX ±0.10	.XX* ±0.5°	MATERILA		DRAW:	
UNITS	mm	FINISH		SCALE SHEET REV.	
				1:1 1/1 A1	