

# 设备安装手册

## 真空皮带脱水机



泰山海伦  
TAI SHAN HAI LUN



山东海伦环保科技发展有限公司

SHAN DONG HELEN ENVIRONMENTAL-PROTECTION SCIENCE & TECHNOLOGY DEVELOPMENT CO.,LTD

# 真空皮带脱水机安装说明

## 一、真空皮带脱水机安装使用环境

1. 设备必须安装于室内环境。
2. 设备基础及围堰应按照基础图纸建设完成。
3. 在基础周围应有3米以上的安装空间。
4. 设备安装必须有起吊设备辅助。
5. 必须具备设备安装工具。
6. 室内安装温度应在零度以上。
7. 安装工人一般应不少于6人。
8. 设备周边2米内应有水电接口，并具备稳定的水源及电源。

## 二、真空皮带脱水机安装所需工具（不限于此）

1. 扳手
2. 铁锤
3. 老虎钳
4. 吊装带
5. 水平仪
6. 施工线
7. 电焊机
8. 千斤顶

## 三、真空皮带脱水机安装注意事项

1. 在转动或其他移动部件周围工作时特别小心，以防伤害自

己或他人。

2. 在安装现场的任何人必须穿戴如安全眼镜、安全鞋和安全帽等安全用品。
3. 严格按照真空皮带脱水机安装手册步骤进行安装。
4. 在安装机架部件时，对设备的平行度和直线度进行严格的检测。
5. 对安装完的辊子，手动转动，确保辊子的正常运转。
6. 在安装过程中不允许吸烟，防止烟头烫伤胶带、滤布等部件。
7. 安装完成后，严格检查设备螺栓的紧固度，并清理现场卫生。

## 四、如在安装过程中遇到疑问请及时致电

电话：0531-87238366

传真：0531-87238366

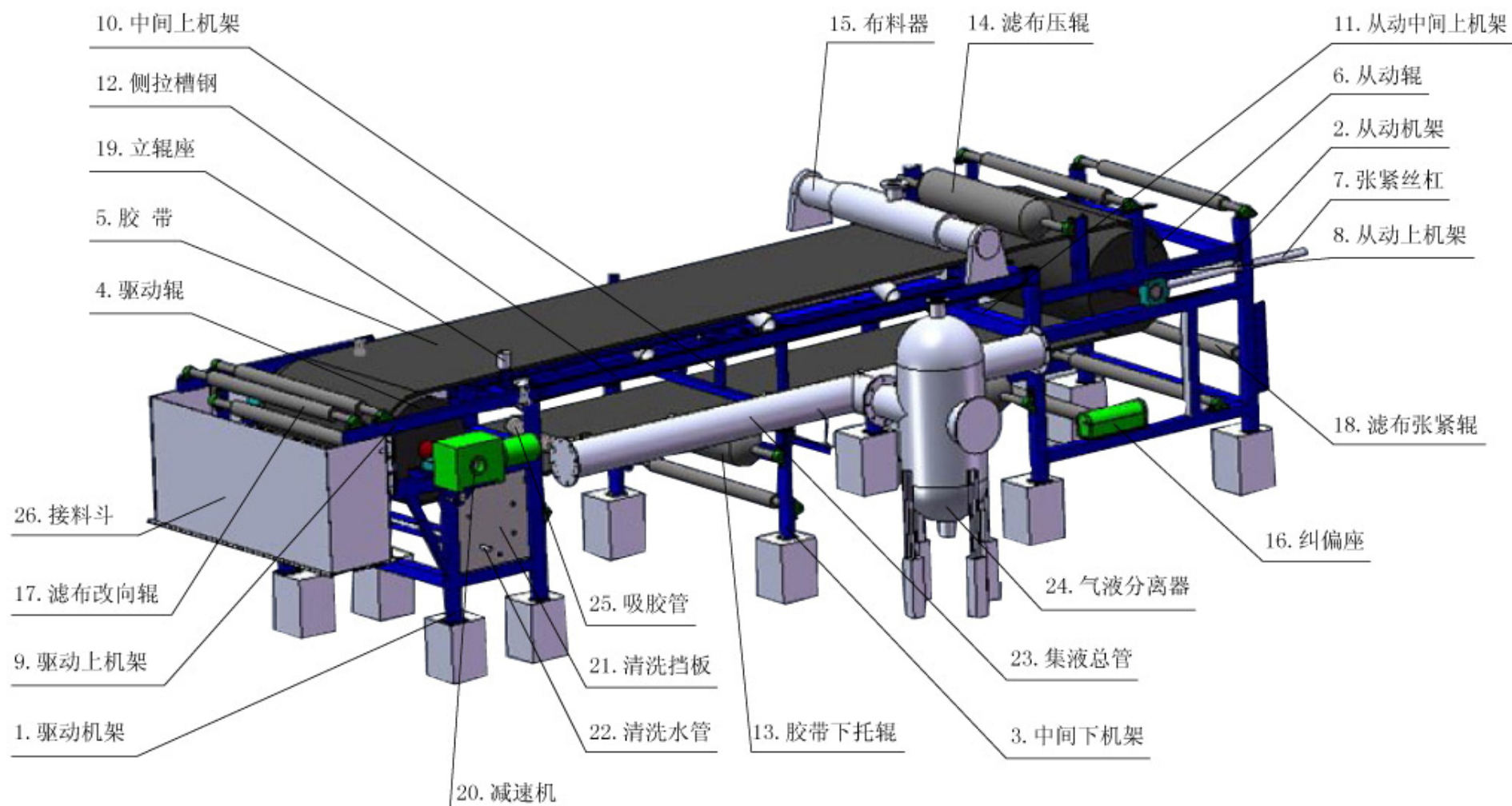

## 一、机架组装

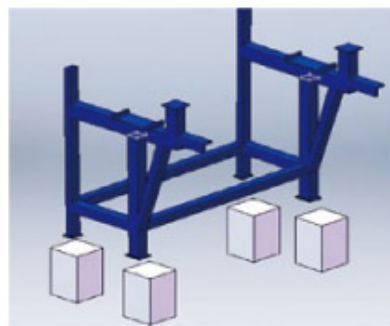
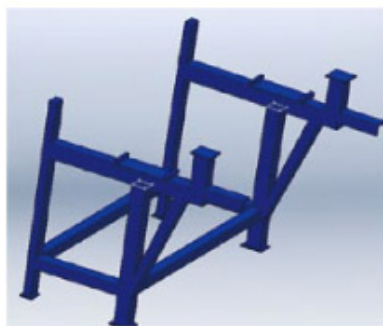

1、根据设备基础载荷图，将驱动机架吊放在驱动端水泥基础上

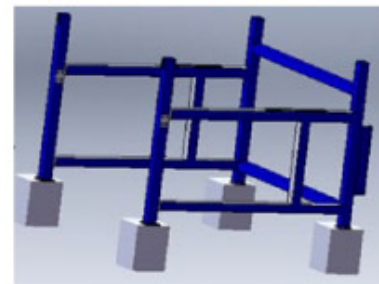
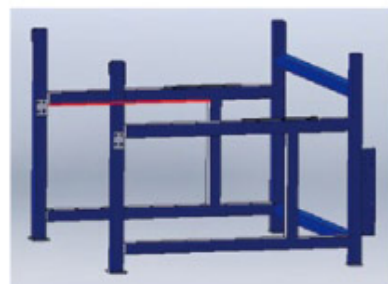

2、将从动机架吊放在从动端水泥基础上

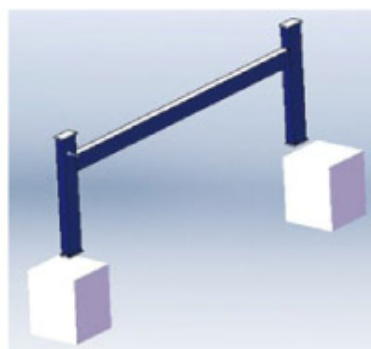
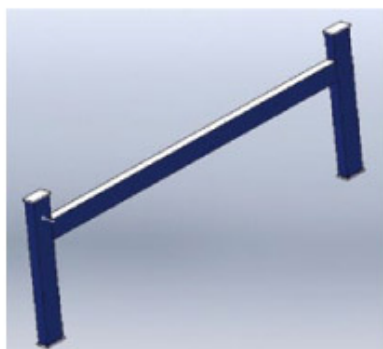

3、将中间下机架吊放在从动端水泥基础上

4、找准三组机架的直线度及平行度，并用焊机将机架稍许固定

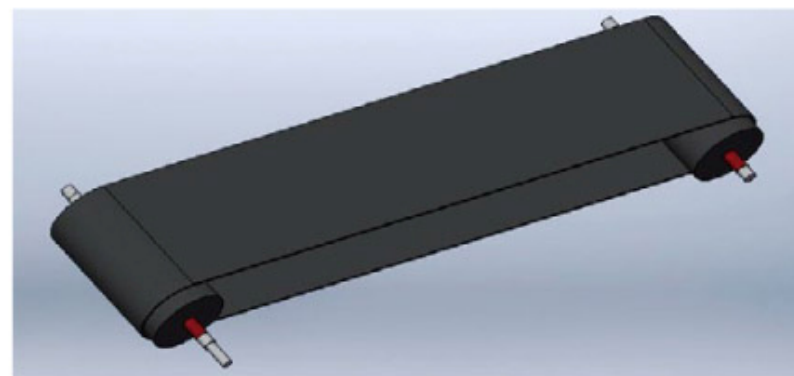

5、将驱动辊和从动辊套入胶带

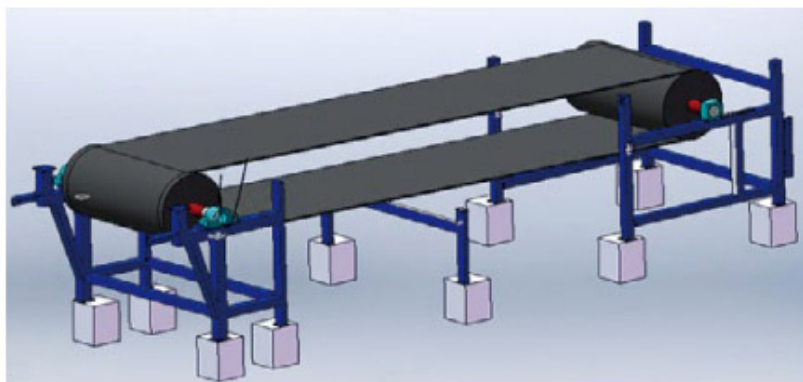

6、将橡胶带及两辊吊入驱动及从动机架

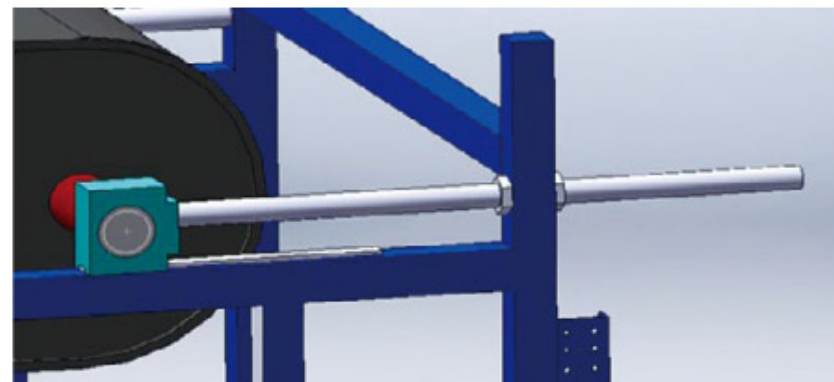

7、装入从动辊张紧丝杠，并安装上锁紧螺丝，用于调整胶带的松紧度

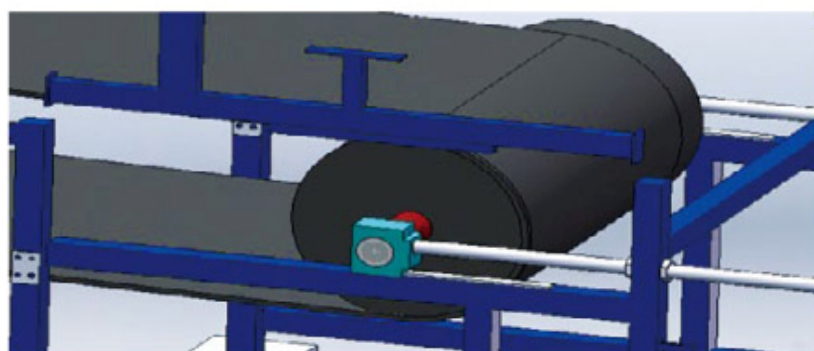

8、装上从动上机架

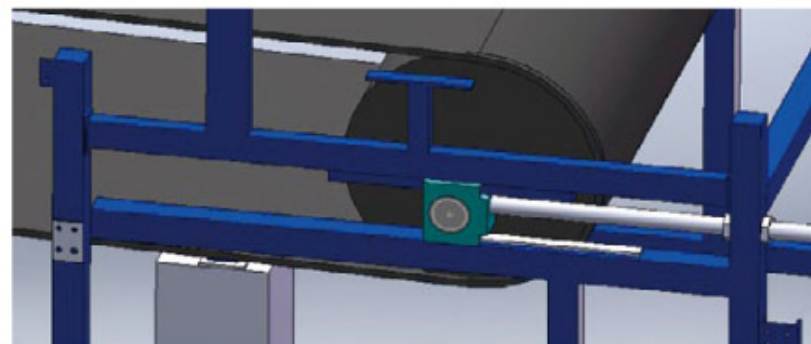

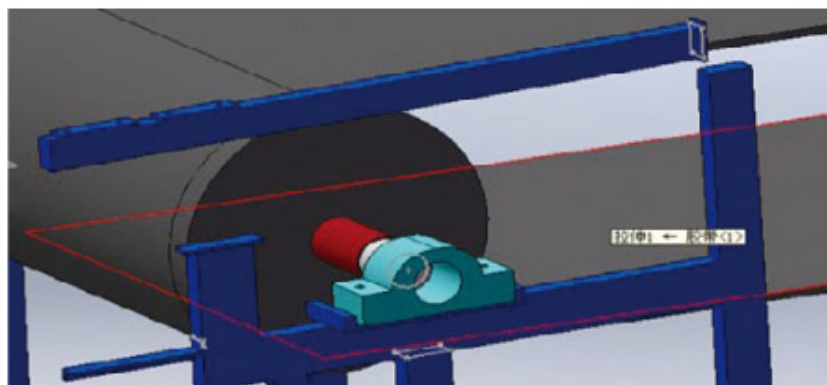

9、装上驱动上机架

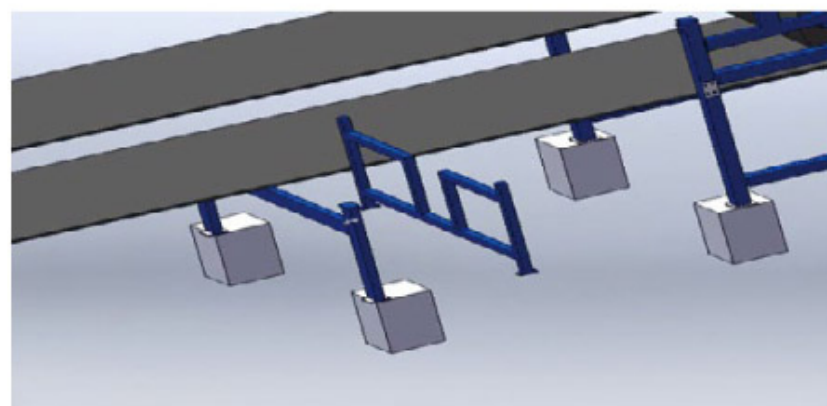
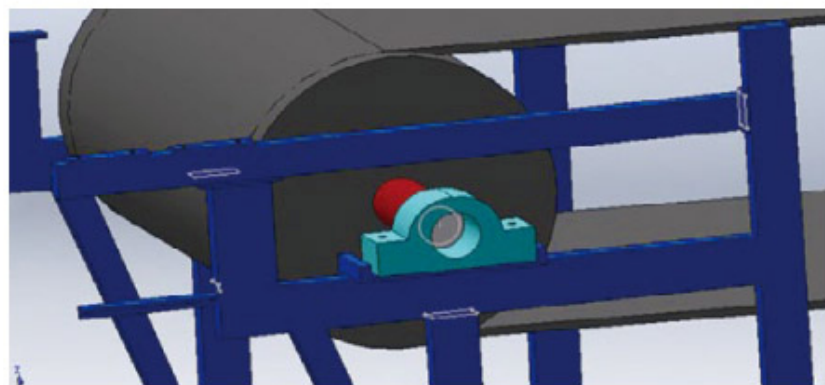

10、装入中间上机架

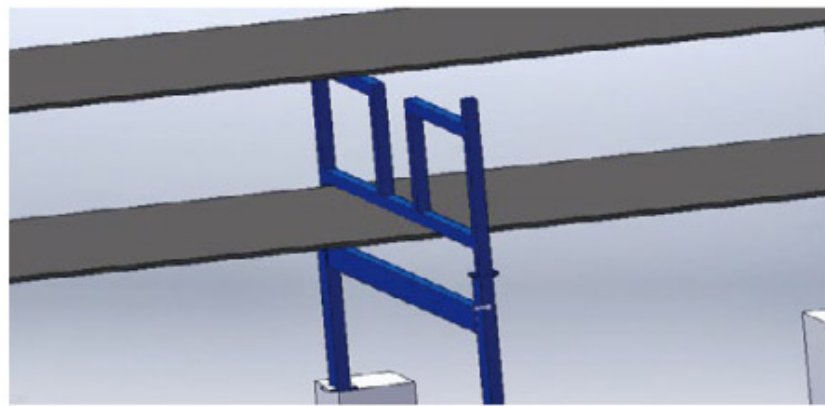

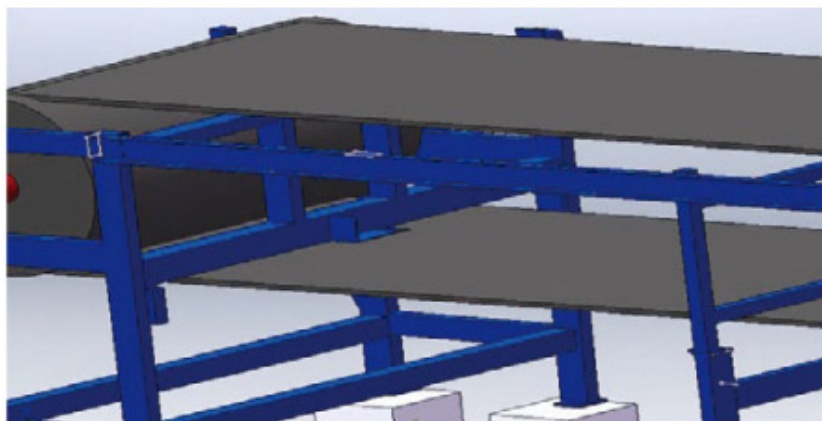

11、安装两侧上机架

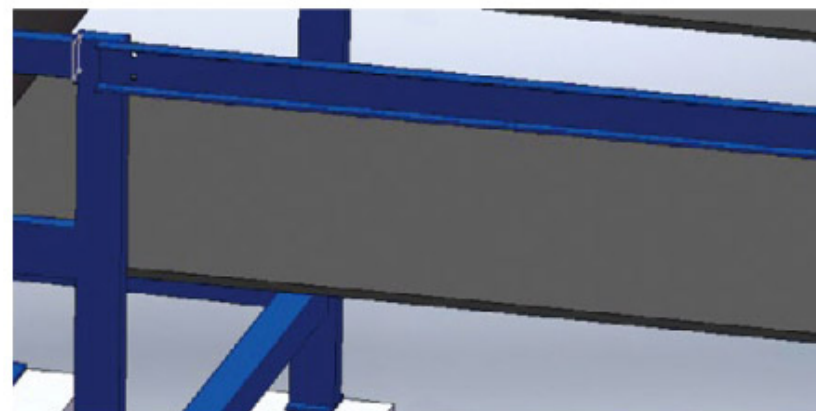

12、安装侧拉槽钢

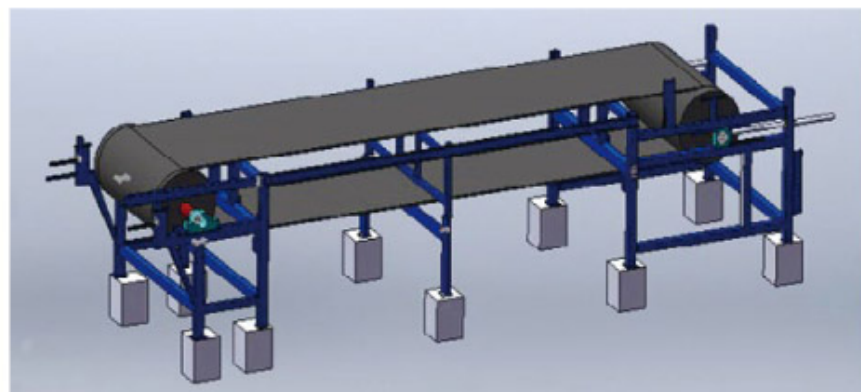

13、测量整个机架的平行度及直线度，并对校正

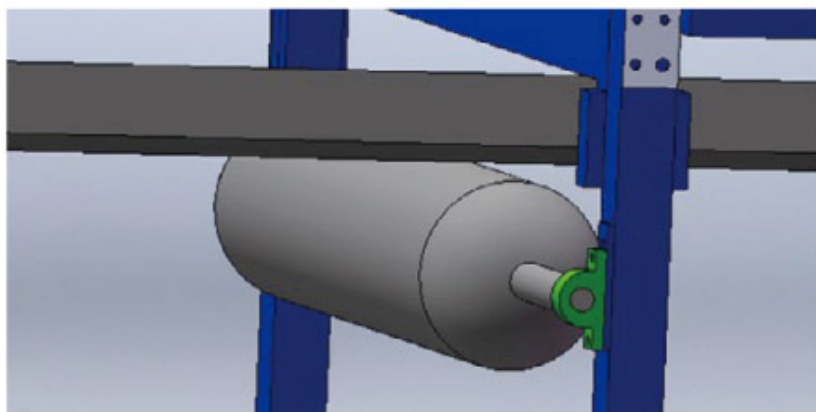

14、安装胶带下托辊安装于下机架

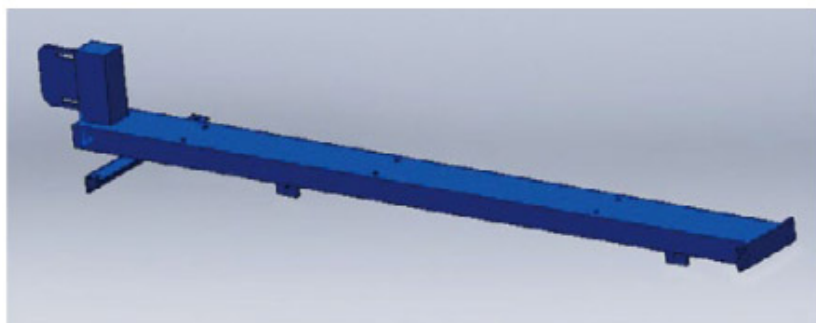
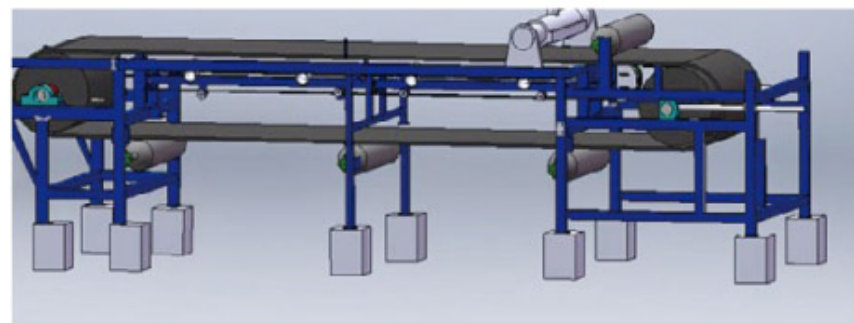

15、将胶带略微吊起，将摩擦带套入真空盒底座，然后将真空盒底座装入设备上机架

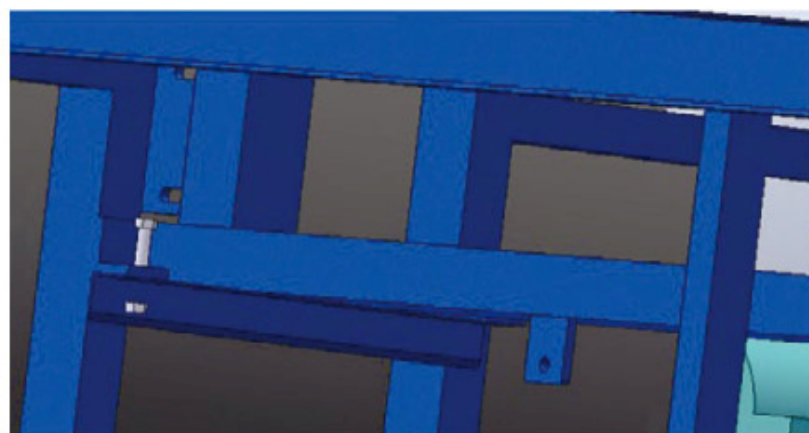

驱动端固定真空盒底座



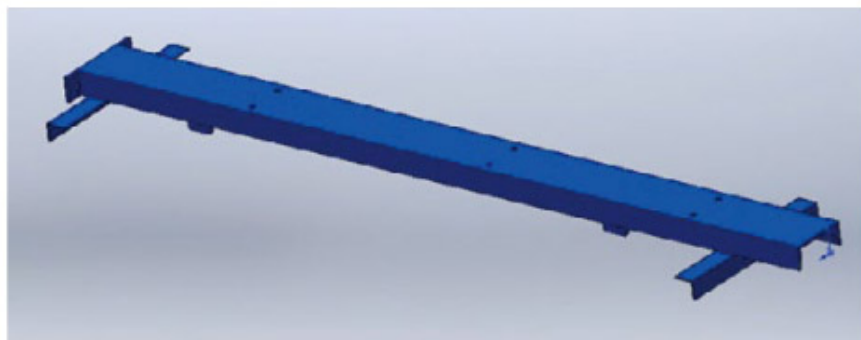

中间段固定真空盒底座

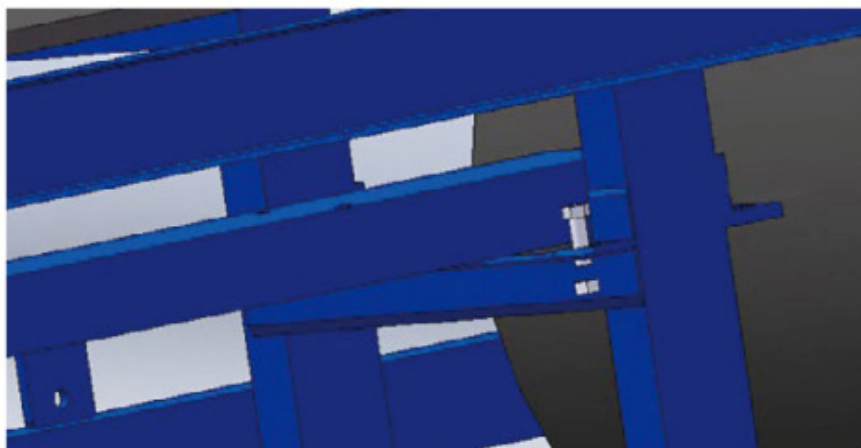
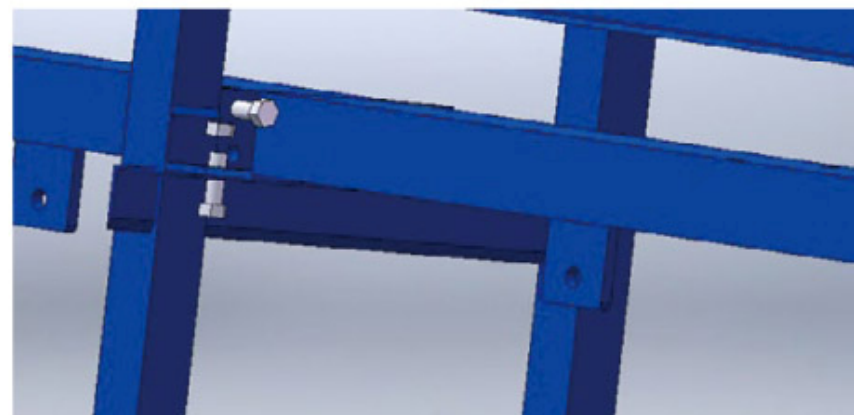

从动端固定真空盒底座

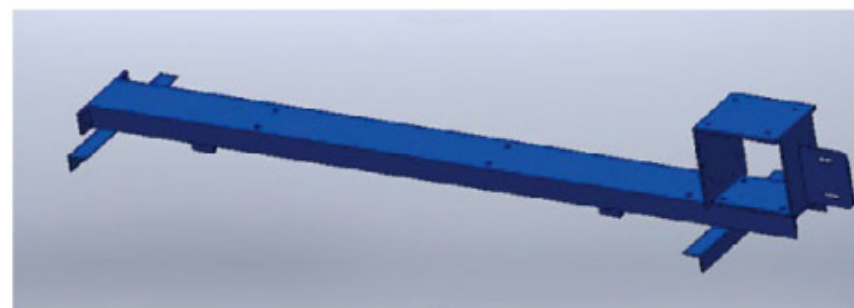

16、将真空盒尾部支架固定固定在真空室支架

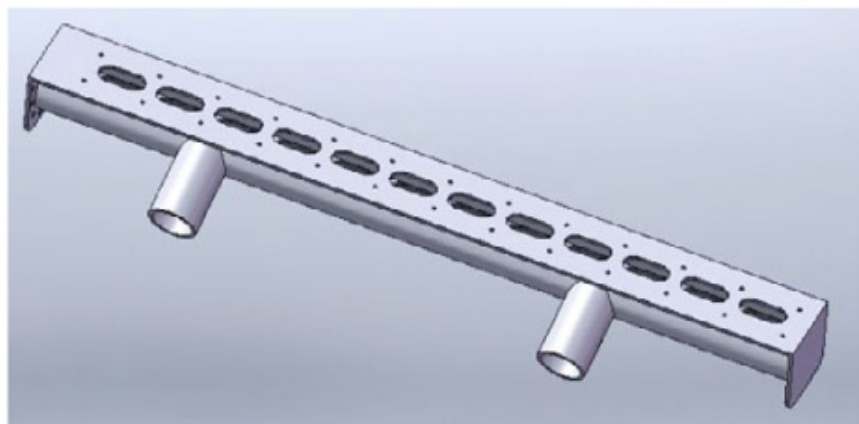

17、在真空盒上部安装滑台，并在中间层加密封垫

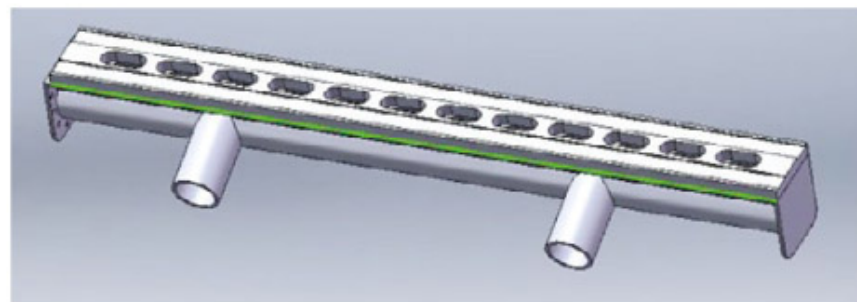

18、将真空盒装入固定基座

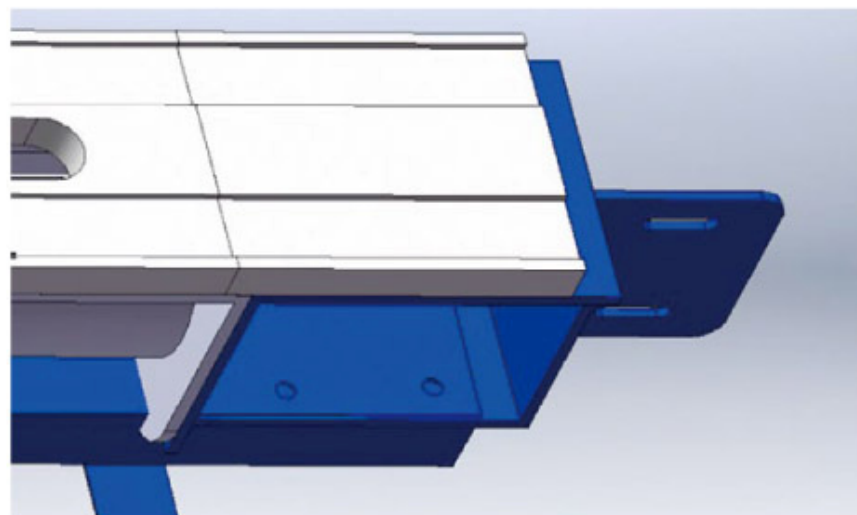

装入端滑台并安装密封垫

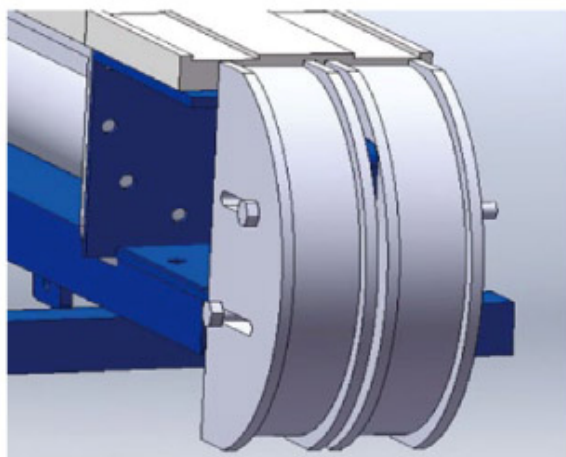

19、头尾两段装上半圆滑块，并用长螺栓上紧

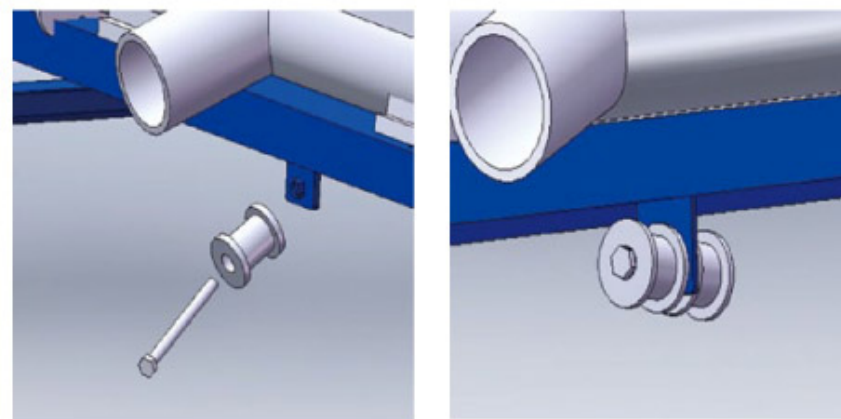

20、将摩擦带导轮用螺栓装入真空盒固定底座

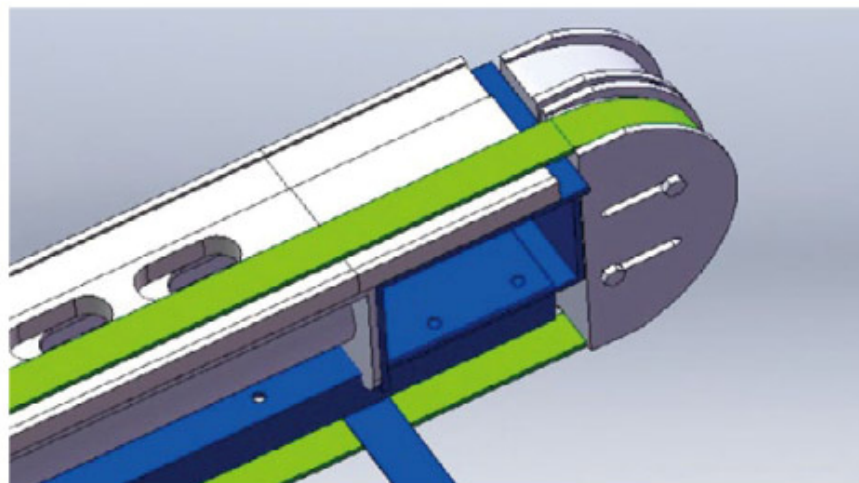

21、将胶带吊起，将摩擦带装入真空滑台凹槽中，并调整

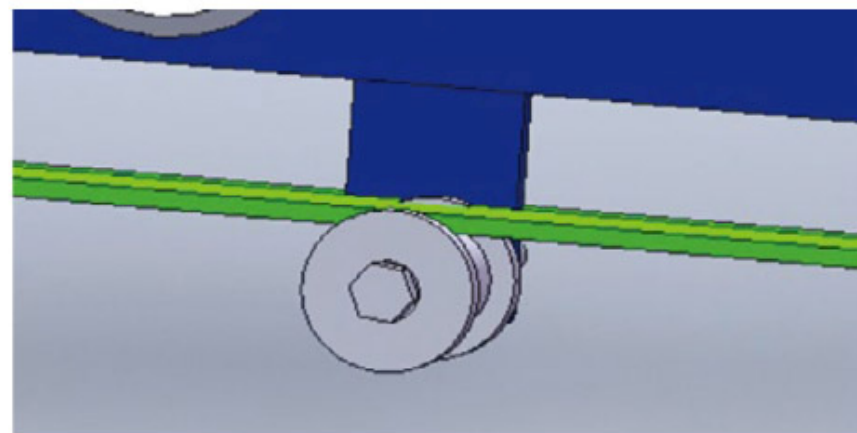

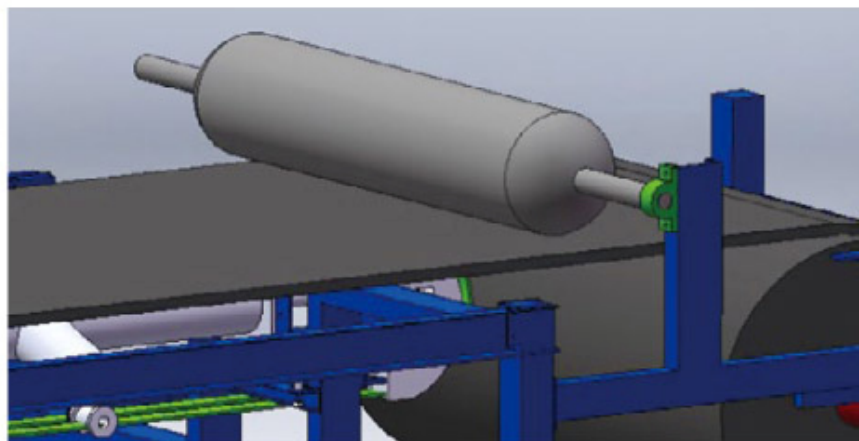

23、安装滤布压辊于槽钢立面

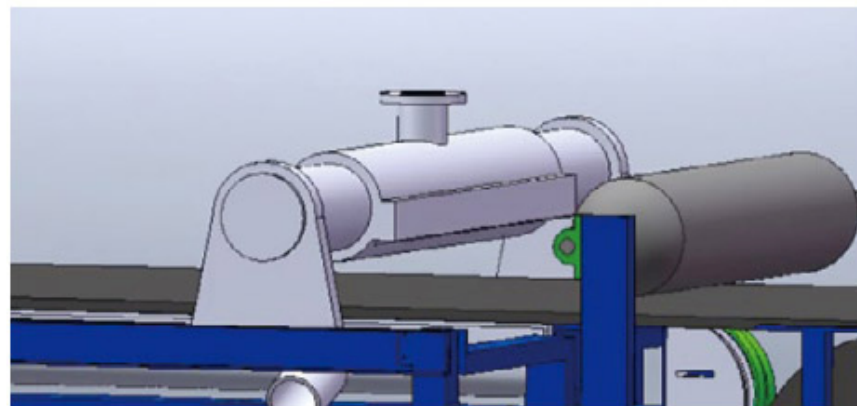

24、安装布料器于侧拉槽钢上

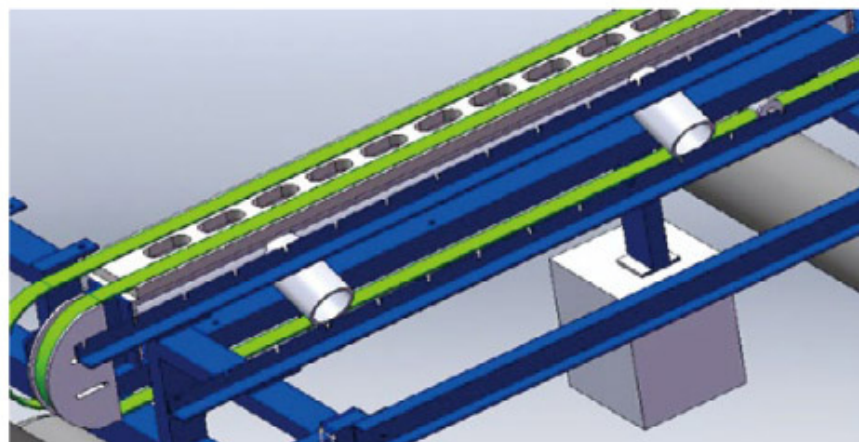

26、安装胶带上托辊支架

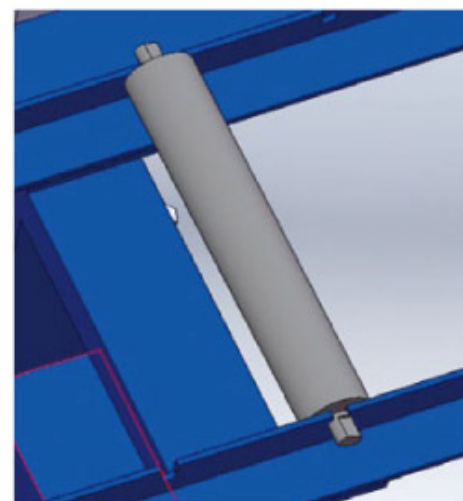

将上托辊逐个安装于支架槽中，并用水平仪找平



27、将纠偏座安装于机架上

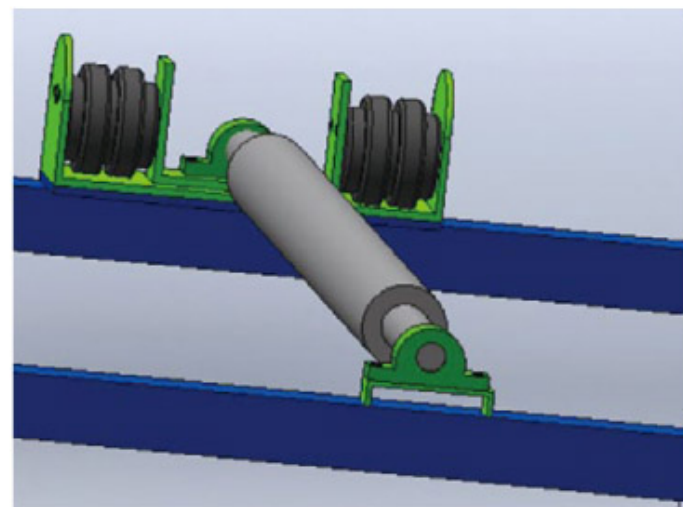

将滤布改向辊安装于纠偏座上

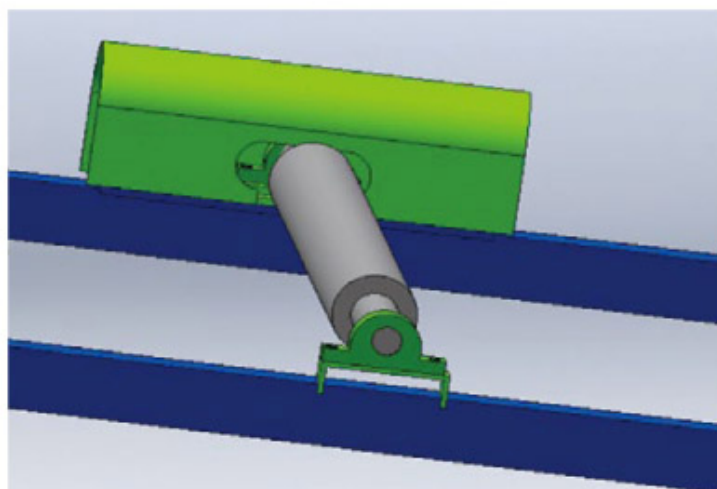

安装纠偏气囊罩

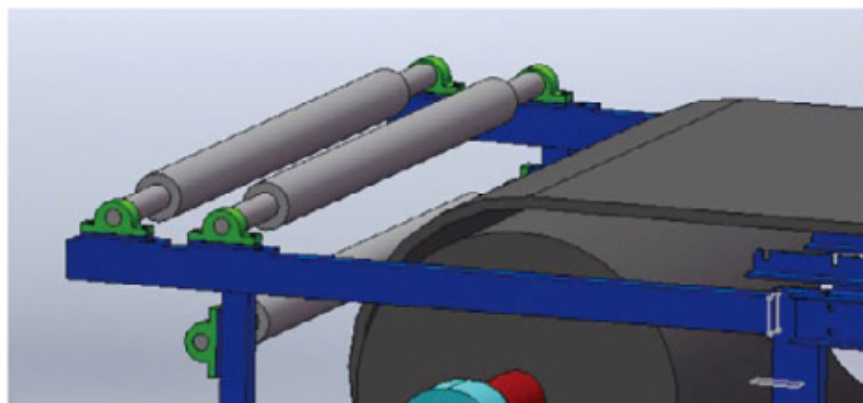

28、安装滤布改向辊:根据装配图纸将滤布改向辊挨个装在机架上

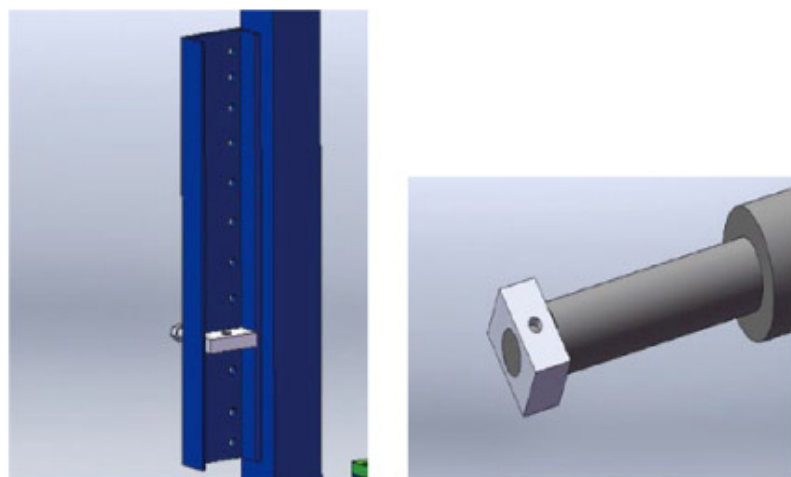
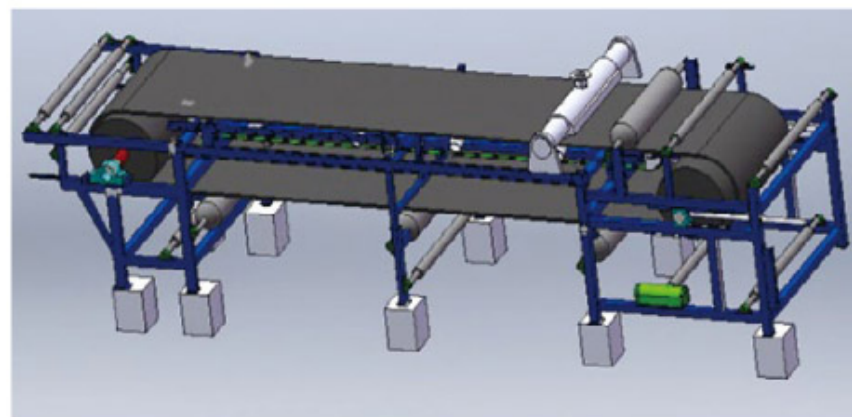

29、安装滤布张紧辊:将固定块用螺栓上入张紧槽钢中

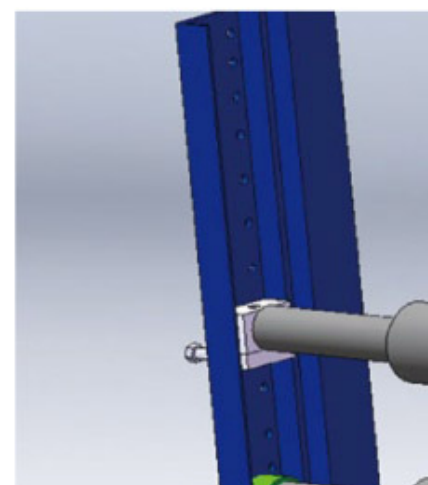

将滤布张紧辊装入固定槽中

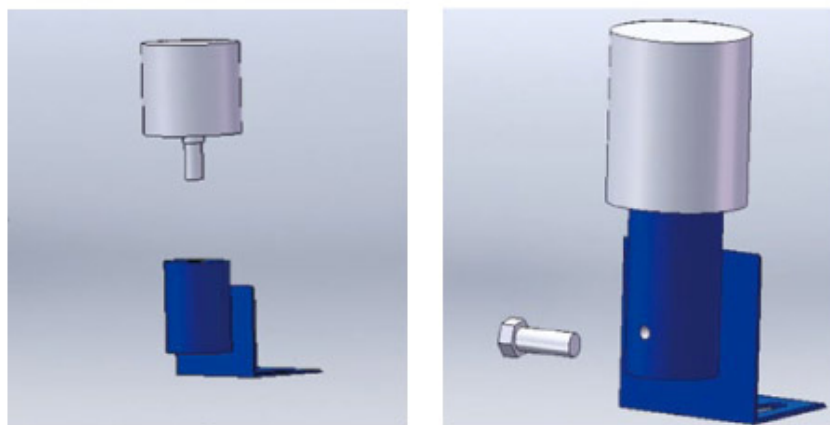

30、将立辊座固定于立辊支架内，并上紧固定销，安装于机架上

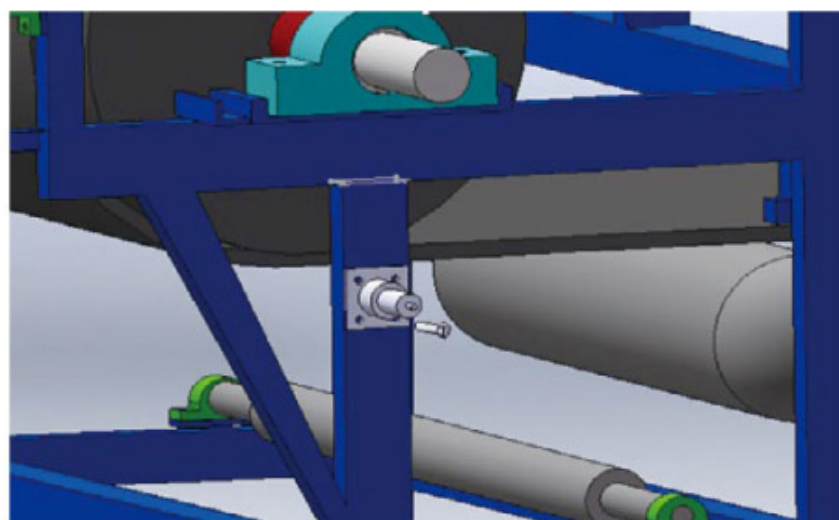
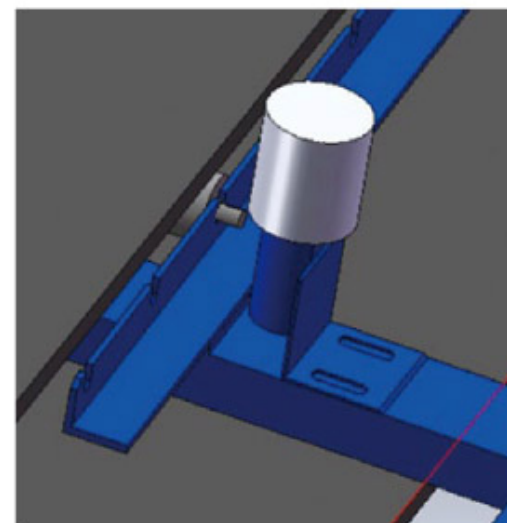

31、安装减速机：将支撑轴安装于机架上

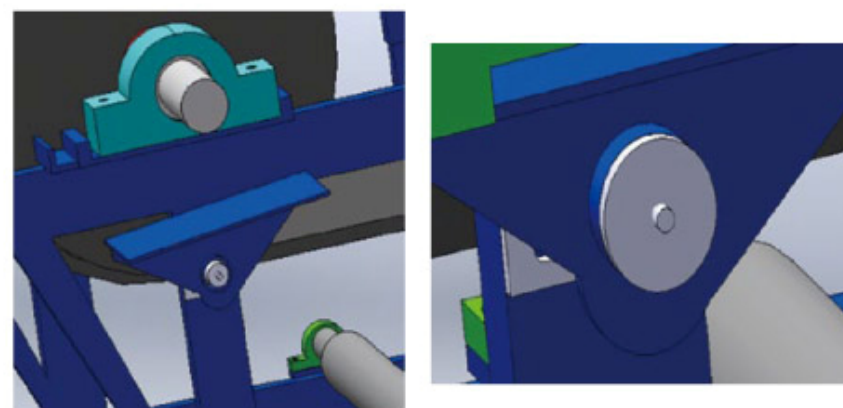

在固定轴上套入固定座，并加装端盖

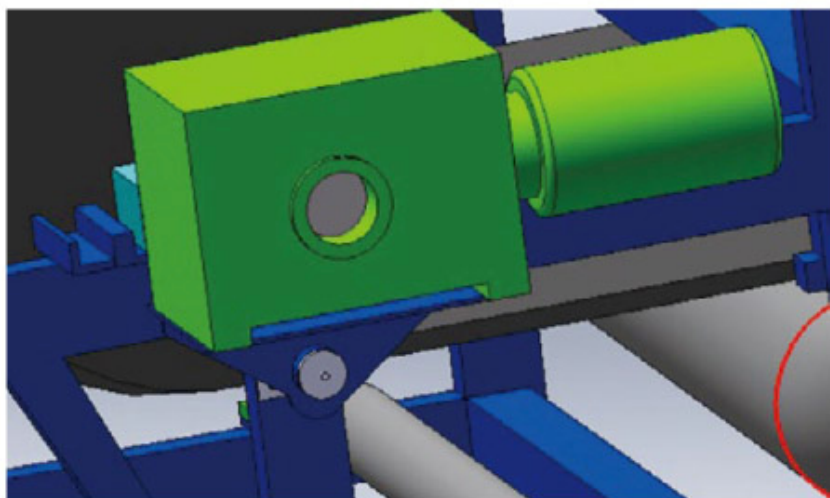

吊入减速机

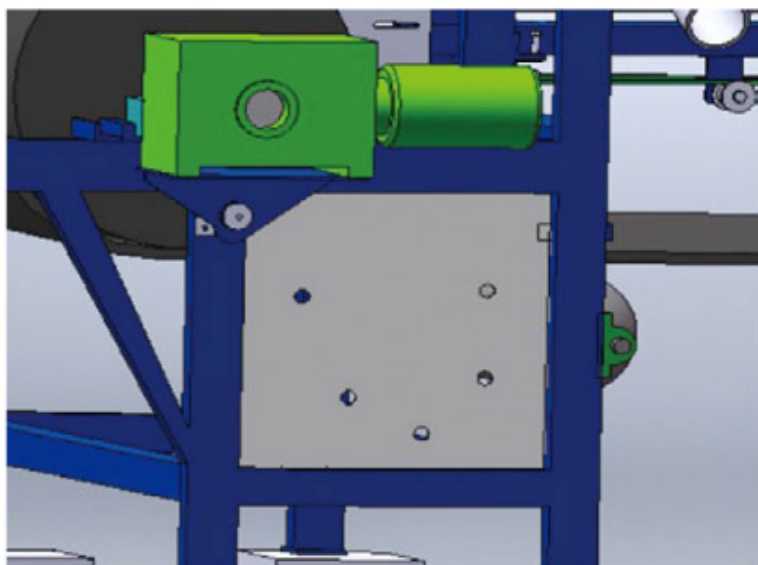
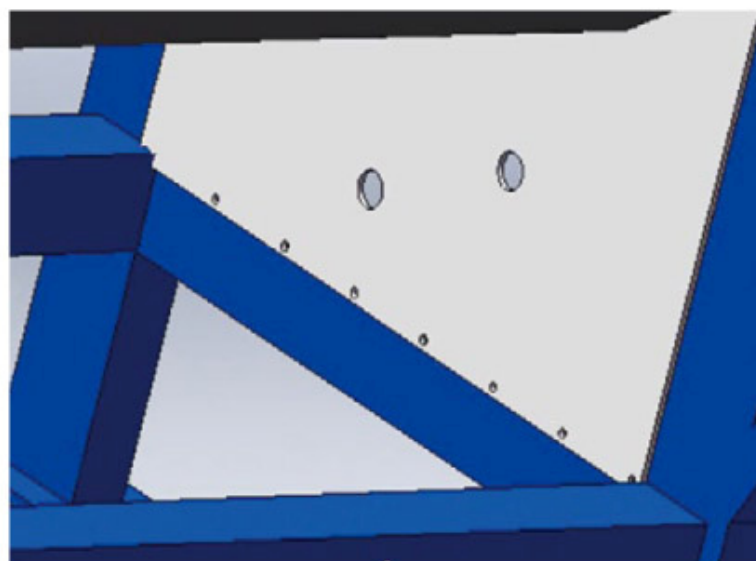



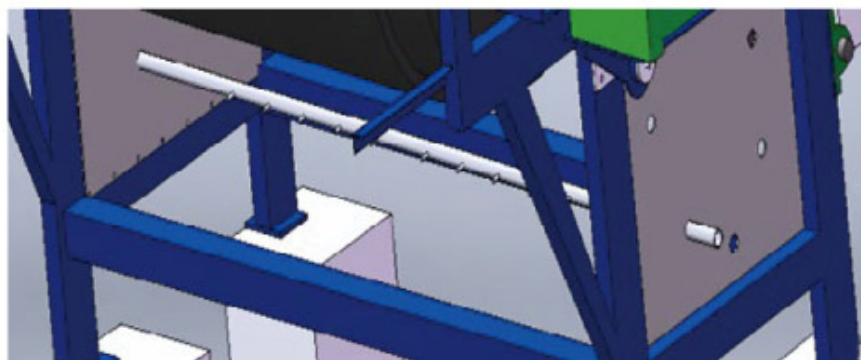

将清洗水管插入清洗挡板的孔中，并在出口端拧上管帽

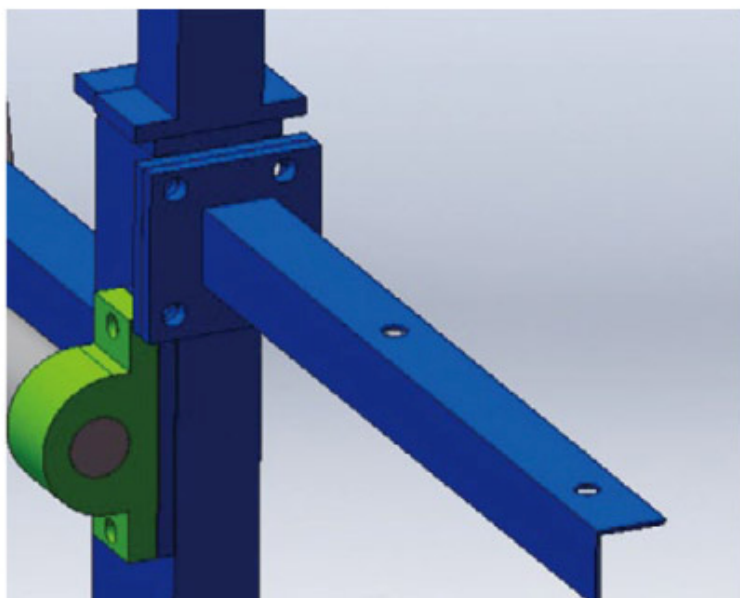
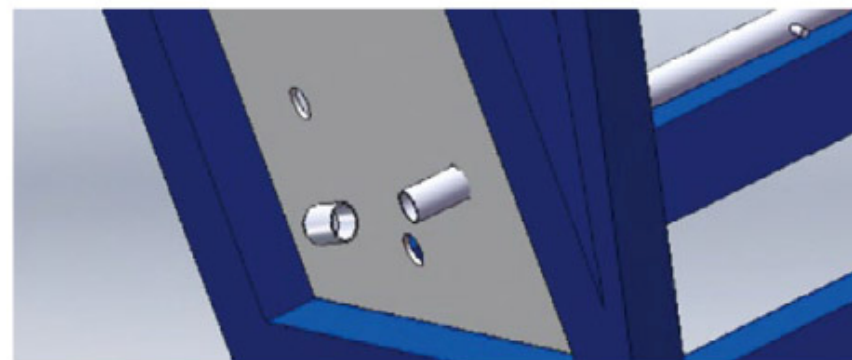

33、安装集液总管：将集液管固定座安装与机架固定板上

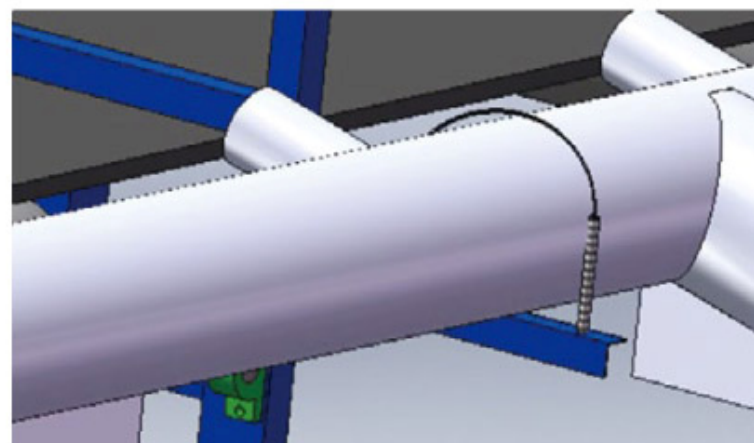

集液总管用钢丝卡箍固定于底座上

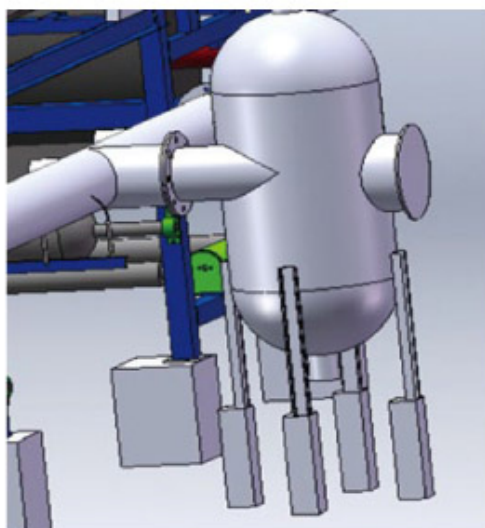

将气液分离器放在支承墩子上，法兰口与集液管法兰口对接

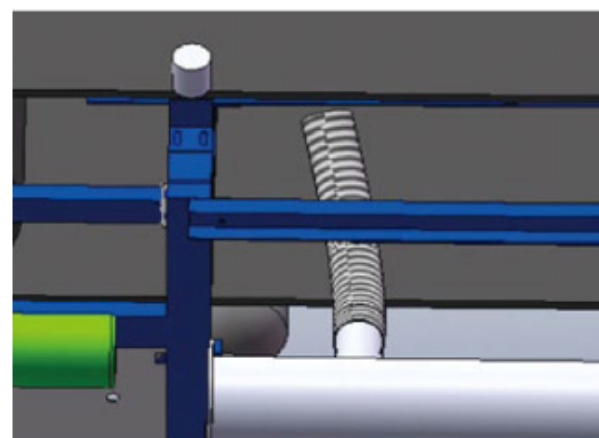

将吸水胶管用钢丝卡箍固定于总管和真空室的管口之间

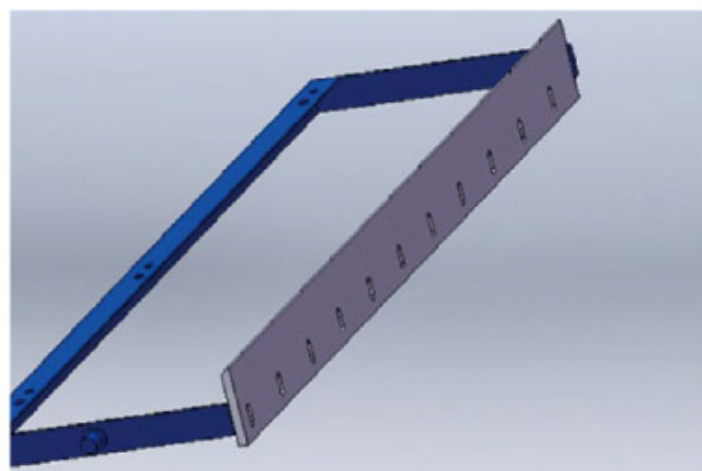

34、安装刮刀：将刮刀板固定于刮刀架上

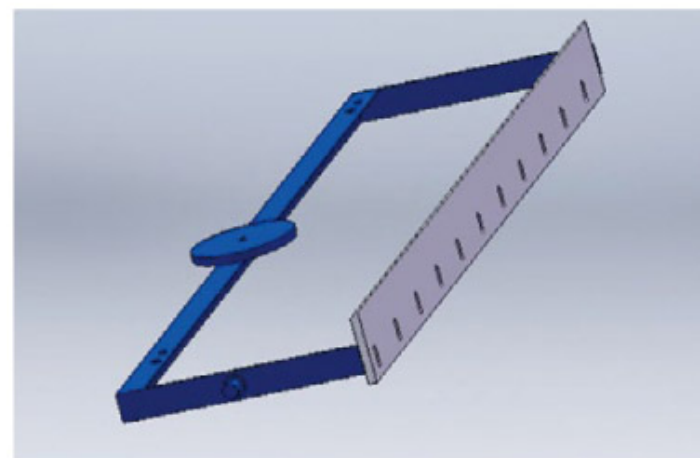

将配重块安装于刮刀机架尾端

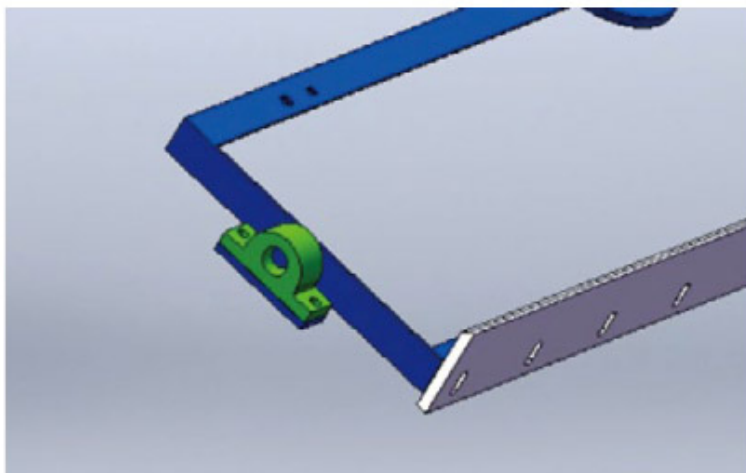

安装轴承座

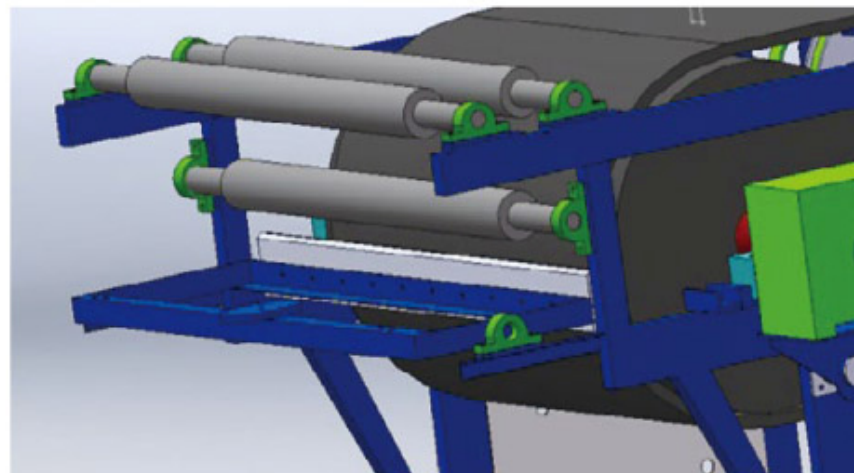

并将刮刀固定于驱动机架尾端

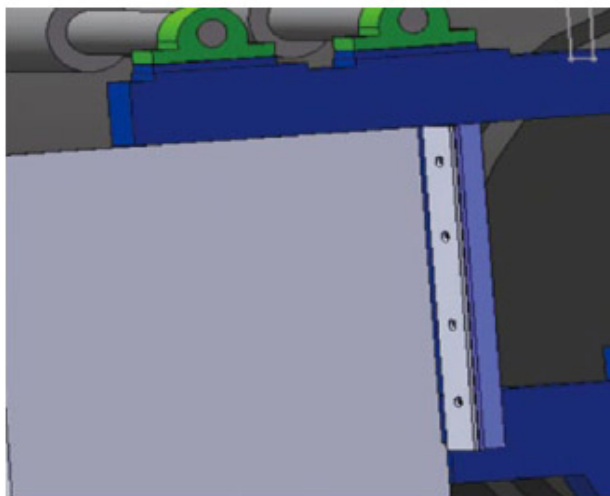

35、将接料斗安装于驱动机架

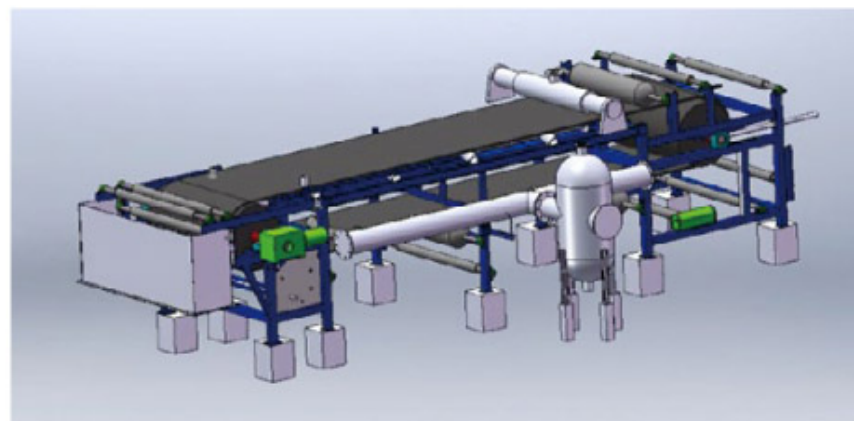

以上螺栓螺帽等紧固件未画出，现场施工人员照配安装。  
整机安装完成，根据我方提供的工艺流程图接管道，根据电器图纸接线。  
如有安装疑问请致电技术部：0531-87350999



山东海伦环保科技有限公司

® SHAN DONG HELEN ENVIRONMENTAL-PROTECTION SCIENCE & TECHNOLOGY DEVELOPMENT CO.,LTD

地址：济南经济开发区南园双玉路7719号

电话：0531-87238166 87368777

传真：0531-87238366

邮编：250300

网址：<http://www.hailunhuanbao.com>

电子信箱：[helenhuanbao@126.com](mailto:helenhuanbao@126.com)

Address: 7719, Shuangyu Road, South District of Jinan Economic Development Zone

Tel: 0531-87238166 87368777

Fax: 0531-87238366

Postcode: 250300

[Http://www.hailunhuanbao.com](http://www.hailunhuanbao.com)

E-mail:[helenhuanbao@126.com](mailto:helenhuanbao@126.com)